

SKLD STUDIO

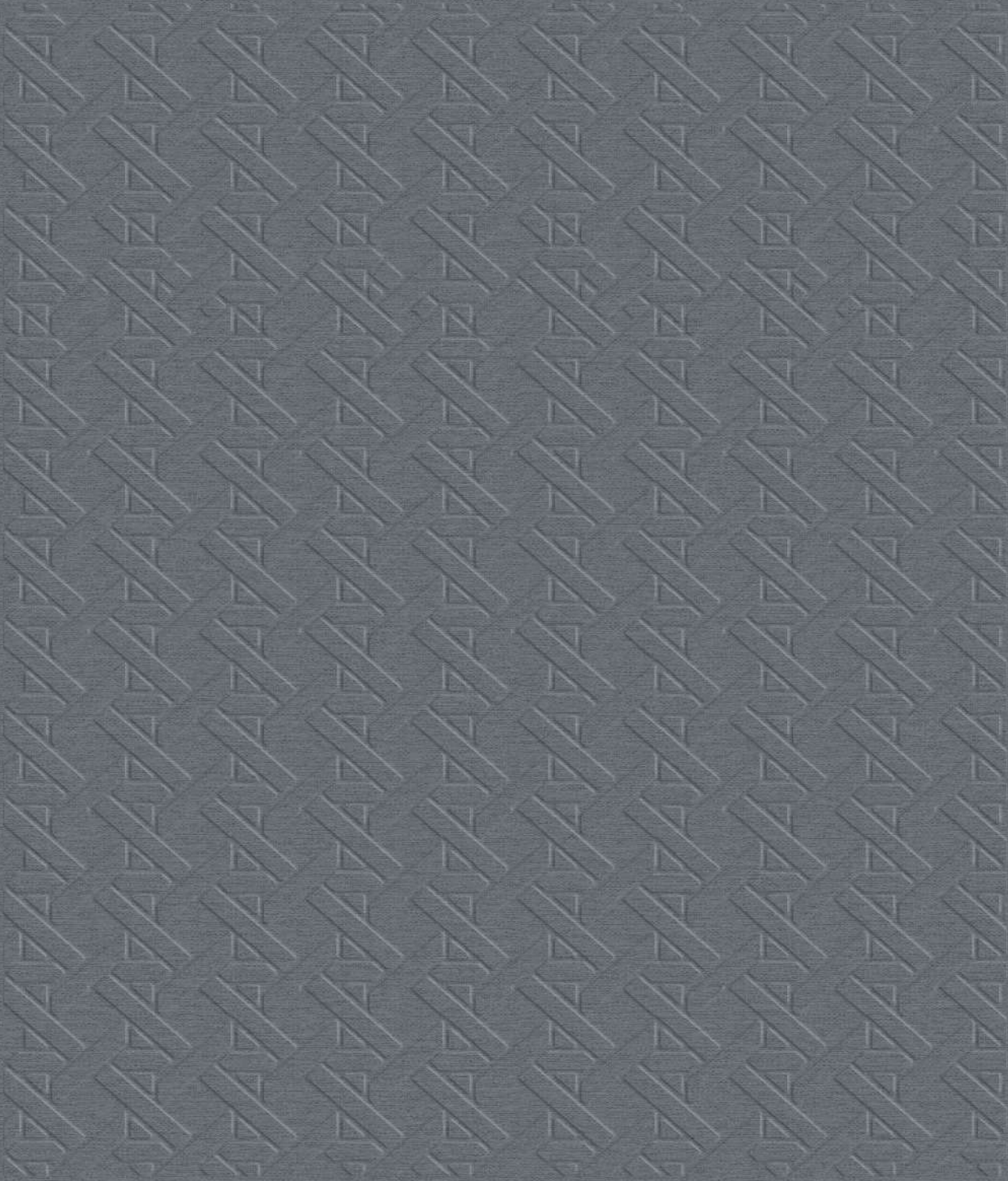

Vol. 1

SKLD STUDIO

by

VOOLCAN
Grupo

Adéntrate en el universo de SKLD Studio y experimenta la síntesis perfecta entre diseño y función, donde cada pieza cuenta una historia de innovación, respaldada por el distintivo sello de calidad de Voolcan Grupo.

Enter the universe of SKLD Studio and experience the perfect synthesis between design and function, where each piece tells a story of innovation, backed by the distinctive quality seal of the Voolcan Group.

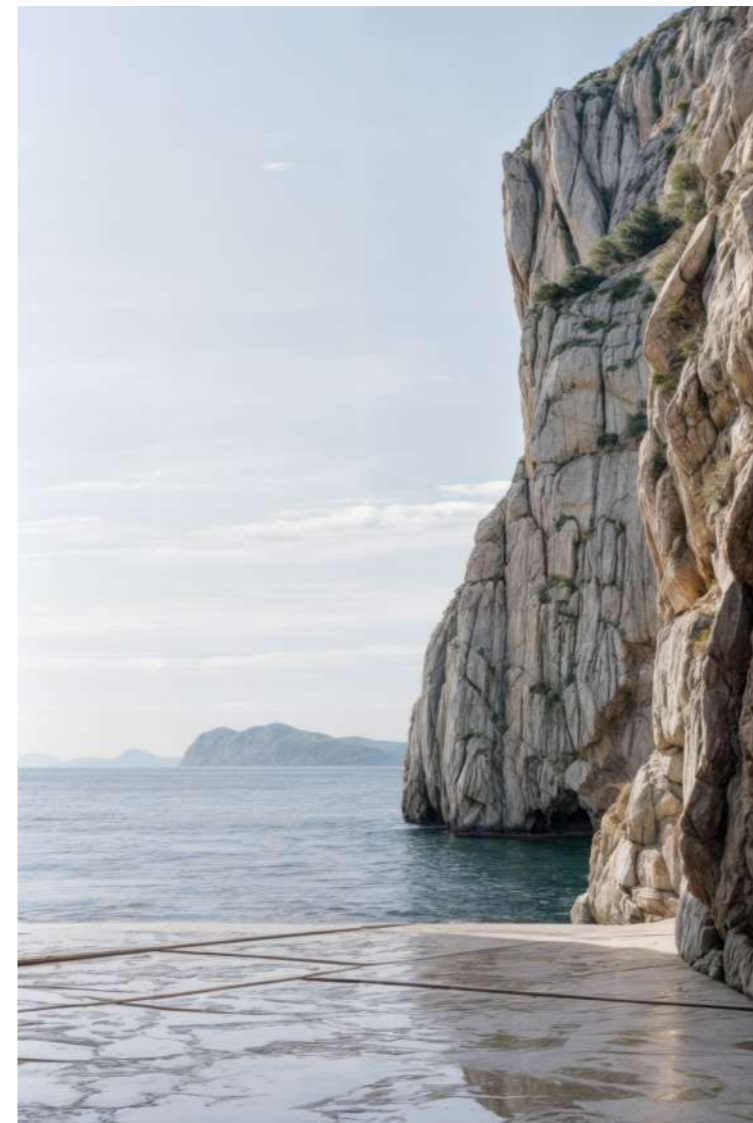

Lo que singulariza a SKLD Studio es su compromiso inquebrantable con la excelencia. La combinación de materiales exclusivos y vanguardistas da vida a piezas singulares y atemporales. Nos enorgullece seleccionar cada componente con meticulosidad, asegurando no solo una estética impactante, sino también una durabilidad y funcionalidad inigualables.

What makes SKLD Studio unique is its unwavering commitment to excellence. The combination of exclusive and avant-garde materials gives life to unique and timeless pieces. We take pride in meticulously selecting each component, ensuring not only stunning aesthetics, but also unmatched durability and functionality.





En este primer volumen, hemos colaborado con renombrados profesionales internacionales del diseño, dotando a cada pieza con su visión única en la creación de mobiliario. El resultado, experiencias estéticas que transforman cualquier espacio en un escenario singular. Llegó la hora de descubrir la esencia de SKLD Studio.

In this first volume, we have collaborated with renowned international design professionals, providing each piece with their unique vision in the creation of furniture. The result, aesthetic experiences that transform any space into a unique setting. It's time to discover the essence of SKLD Studio.

index

tempo

10

umbra

42

lacus

72

lenis

96

ventus

120

materials

142

tempo collection by la mamba

Tempo es un proyecto que surge de la combinación de ligereza, modularidad y confort en el exterior, creando situaciones de relax y desconexión. La estructura de aluminio con cuerda entrelazada es el hilo conductor de toda la colección. Un diseño envolvente que se acompaña de grande cojines acolchados con la finalidad de sentirse recogido.

Tempo is a project that emerge from the combination of lightness, modularity and comfort on the outdoors, creating situations of relax and disconnection. The aluminum structure with the weaved rope is the common thread of the entire collection. An enveloping design that is accompanied by large quilted cushions in order to feel wrapped.







01.



02.



03.

01. Sofa.

02. Loveseat.

03. Armchair.

diseñadores
designers



01.



03.

la mamba



En La Mamba respiramos diseño. Entendemos el diseño desde una perspectiva armonizada y global. De la mano de nuestro cliente, definimos la estética, la funcionalidad y la comunicación de cada producto, desde un punto de vista humanista y lógico que abre nuevos horizontes. Estamos especializados en diseño de productos, dirección de arte, interiorismo, branding, arquitectura efímera, dirección artística y consultoría estratégica para empresas. Funcionalidad, sensibilidad, serenidad, equilibrio y sutileza de Wevbring para cada proyecto, que concebimos y desarrollamos de principio a fin.

In La Mamba we breathe design. We understand design from a harmonized and global perspective. Hand in hand with our client, we define the aesthetics, the functionality and the communication of each product, from a humanist and logical point of view that opens new horizons. We are specialized in product design, art direction, interiorism, branding, ephemeral architecture, artistic direction and strategic consultancy for companies. We bring functionality, sensitivity, serenity, balance and subtlety to every project, that we conceive and develop from beginning to end.



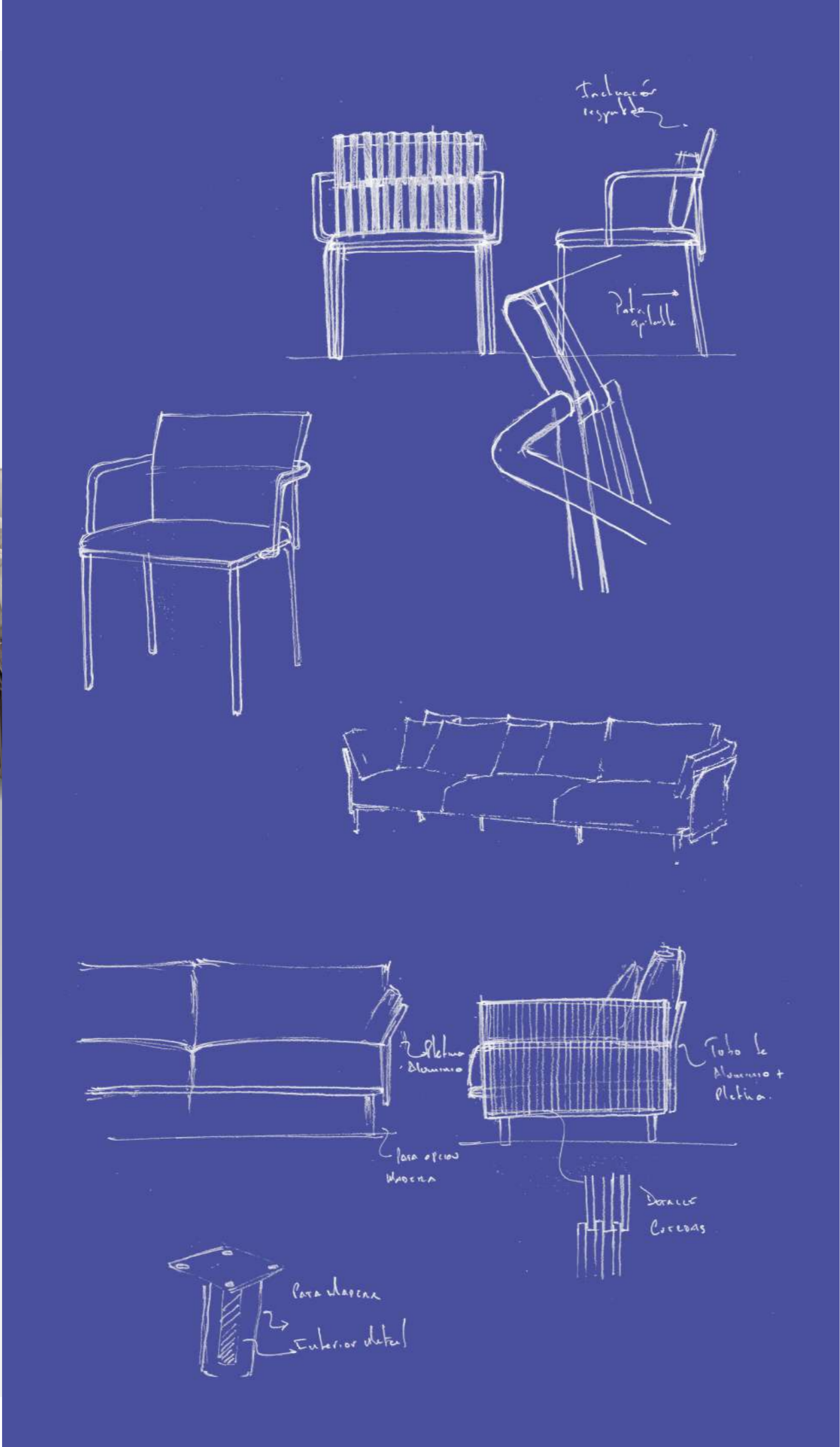

01. Sofa.

02. Loveseat.

03. Armchair.



04. Central table module 45°.







05.

05. Right chaise longue + Left chaise longue.







06.



07.

06. Daybed.

07. Right chaise longue + Left chaise longue.



08.

08. Single lounge with wheels.



09.

09. Dining armchair.





10. Rectangular dining table 300.

11. Rectangular dining table 240.



10.



11.



12.



13.

12. Round coffee table.

13. Round side table.



14.

14. Rectangular coffee table.



15.

15. Square coffee table.

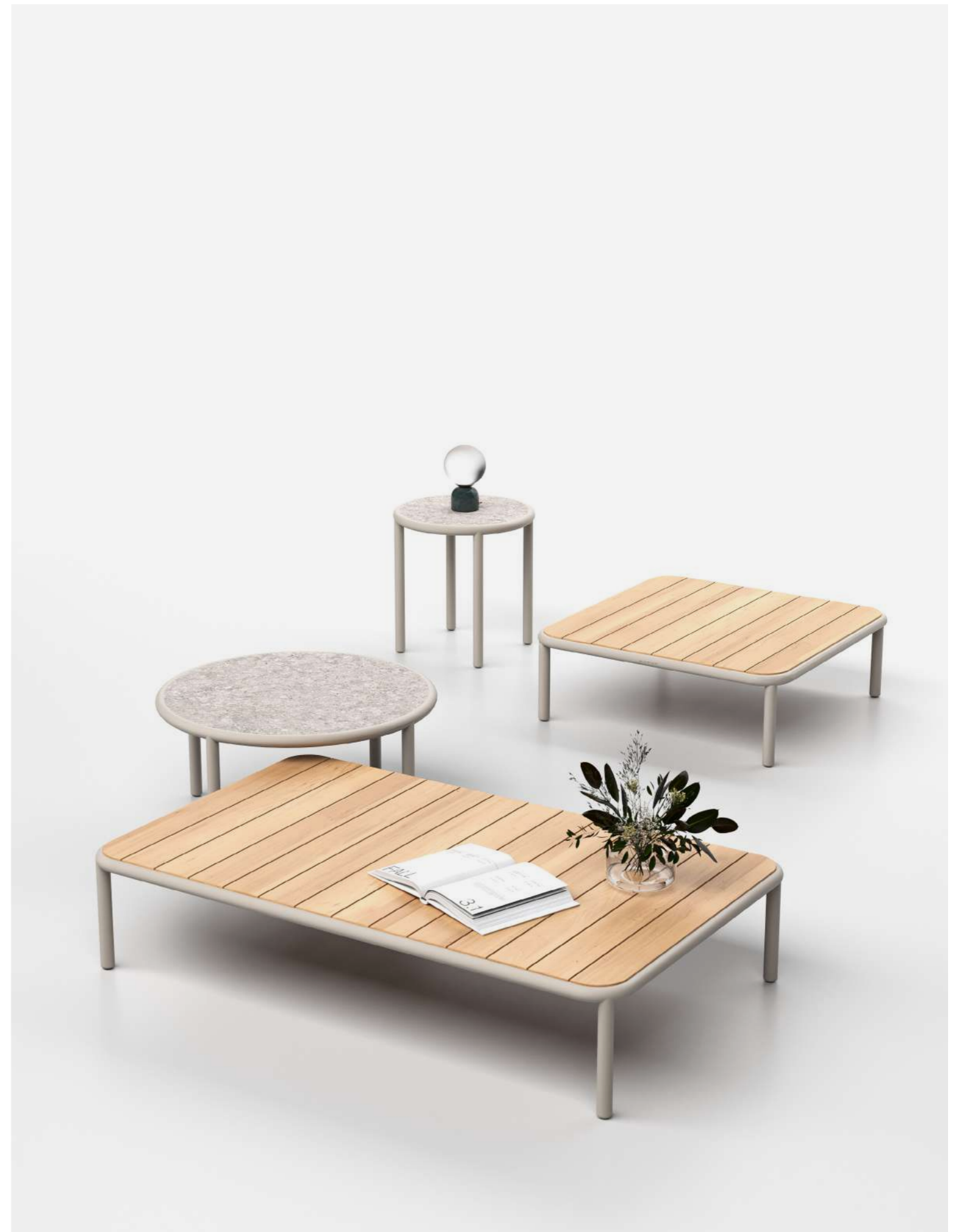

technical

MATERIALS



Madera de teca
Teak wood



Aluminio *Aluminium*
White Wash

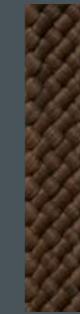

Cuerda plana *Flat rope*
Atmosphere

[24361] ARMCHAIR

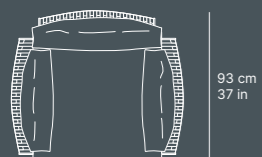

106 cm
41 in

[24362] LOVESEAT

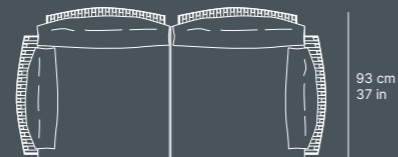

186 cm
73 in

[24366.01] RIGHT CHAISE LONGUE

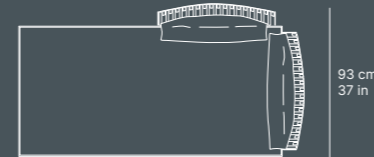

173 cm
68 in

[24366] LEFT CHAISE LONGUE

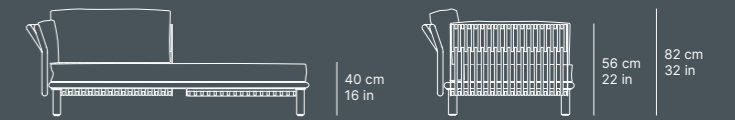

173 cm
68 in

[24363] SOFA

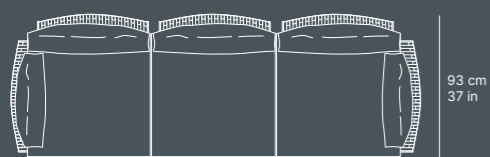

266 cm
105 in

[24383] CENTRAL TABLE MODULE 45°

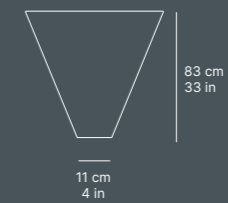

technical

MATERIALS



Madera de teca
Teak wood



Aluminio *Aluminium*
White Wash



Cuerda plana *Flat rope*
Atmosphere

[24369] DAYBED

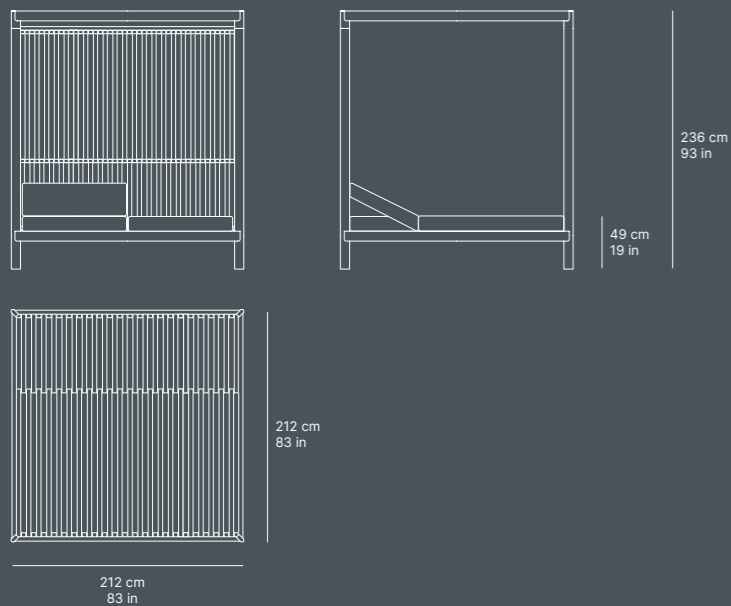

[24368] SINGLE LOUNGER WITH WHEELS

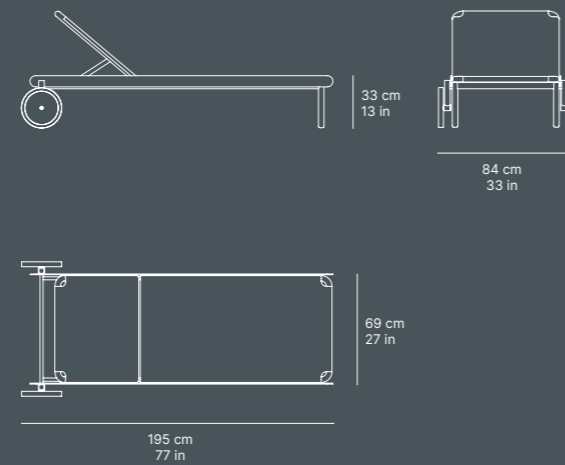

[24360] DINING ARMCHAIR

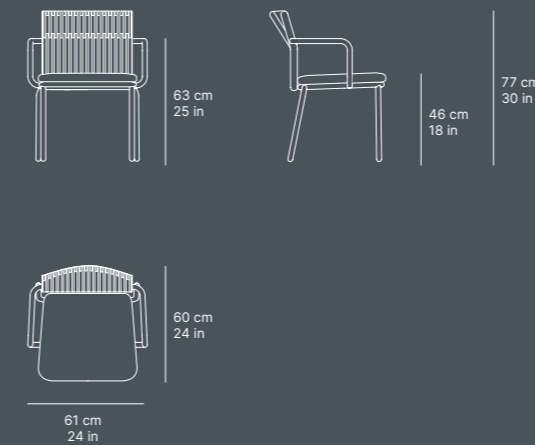

technical

MATERIALS



Madera de teca
Teak wood



Aluminio *Aluminium*
White Wash



Cuerda plana *Flat rope*
Atmosphere

[24367.01] RECTANGULAR DINING TABLE 300

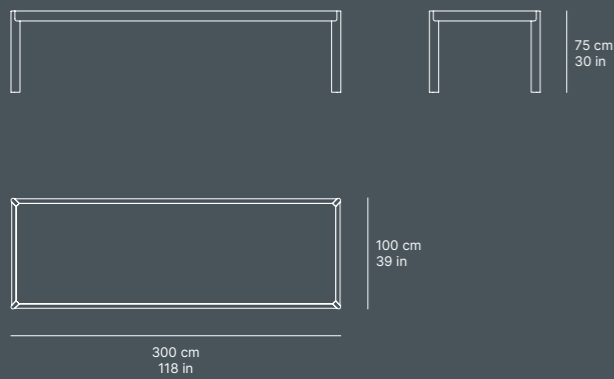

[24367] RECTANGULAR DINING TABLE 240

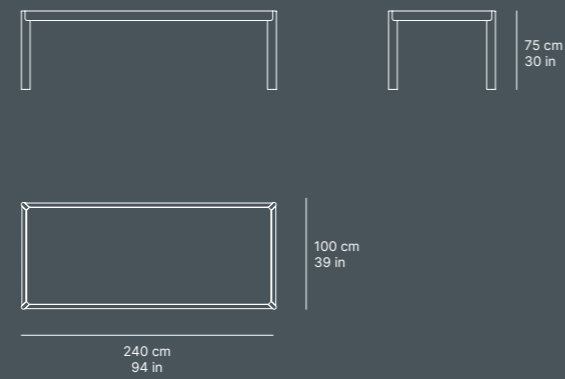

[24364] SQUARE COFFEE TABLE

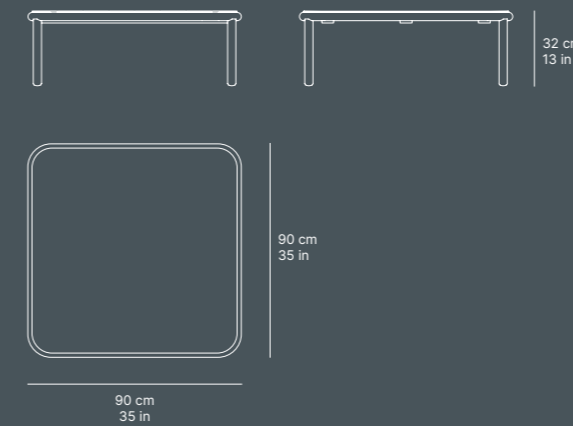

[24365] ROUND SIDE TABLE

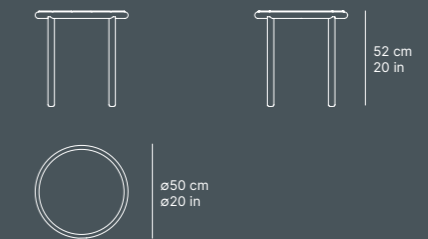

[24364.01] RECTANGULAR COFFEE TABLE

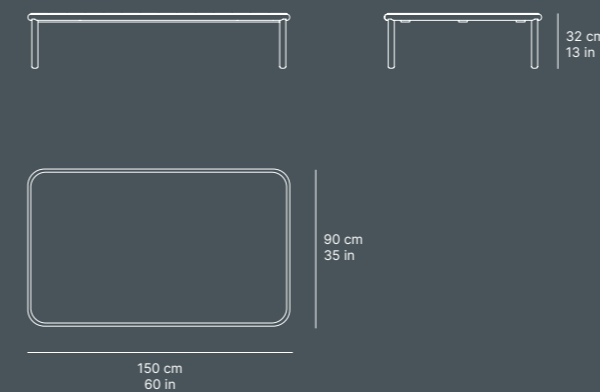

[24364.02] ROUND COFFEE TABLE

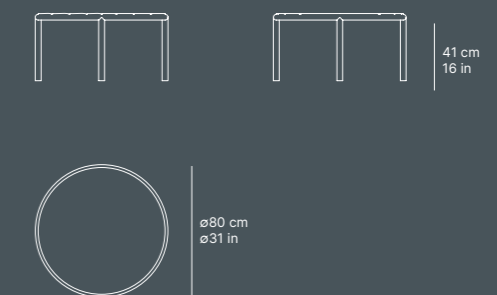

umbra collection by adam johnston

Umbr es una confluencia de tradición, artesanía y diseño. Tomando inspiración de sillas tejidas vernaculares y sillas de palo de diversas regiones de las Islas Británicas, Umbr a combina teca con fibras tejidas para crear una colección contemporánea de muebles de exterior.

Umbr a is a confluence of tradition, craft and design. Taking cues from vernacular woven chairs and stick chairs from around the British Isles, Umbr a combines the use of teak wood and woven fibres to create a contemporary collection of outdoor furniture.







01.



02.



03.

01. Sofa.

02. Loveseat.

03. Armchair.





diseñador
designer

adam
johnston



Adam Johnston es un diseñador escocés, basado entre Barcelona y el Reino Unido.

Influenciado por su internacionalidad, su enfoque simple y considerado define su estudio. Con interés tanto en la artesanía y los procesos industriales, diseña objetos cotidianos, muebles e interiores para clientes de distintos países.

Adam Johnston is a Scottish designer, based between Barcelona and the UK.

Influenced by his international background, his simple and considered approach informs his practice. With an interest in both craft and industrial processes, he works on everyday objects, furniture and interiors for clients across multiple countries.



04.

04. Daybed.

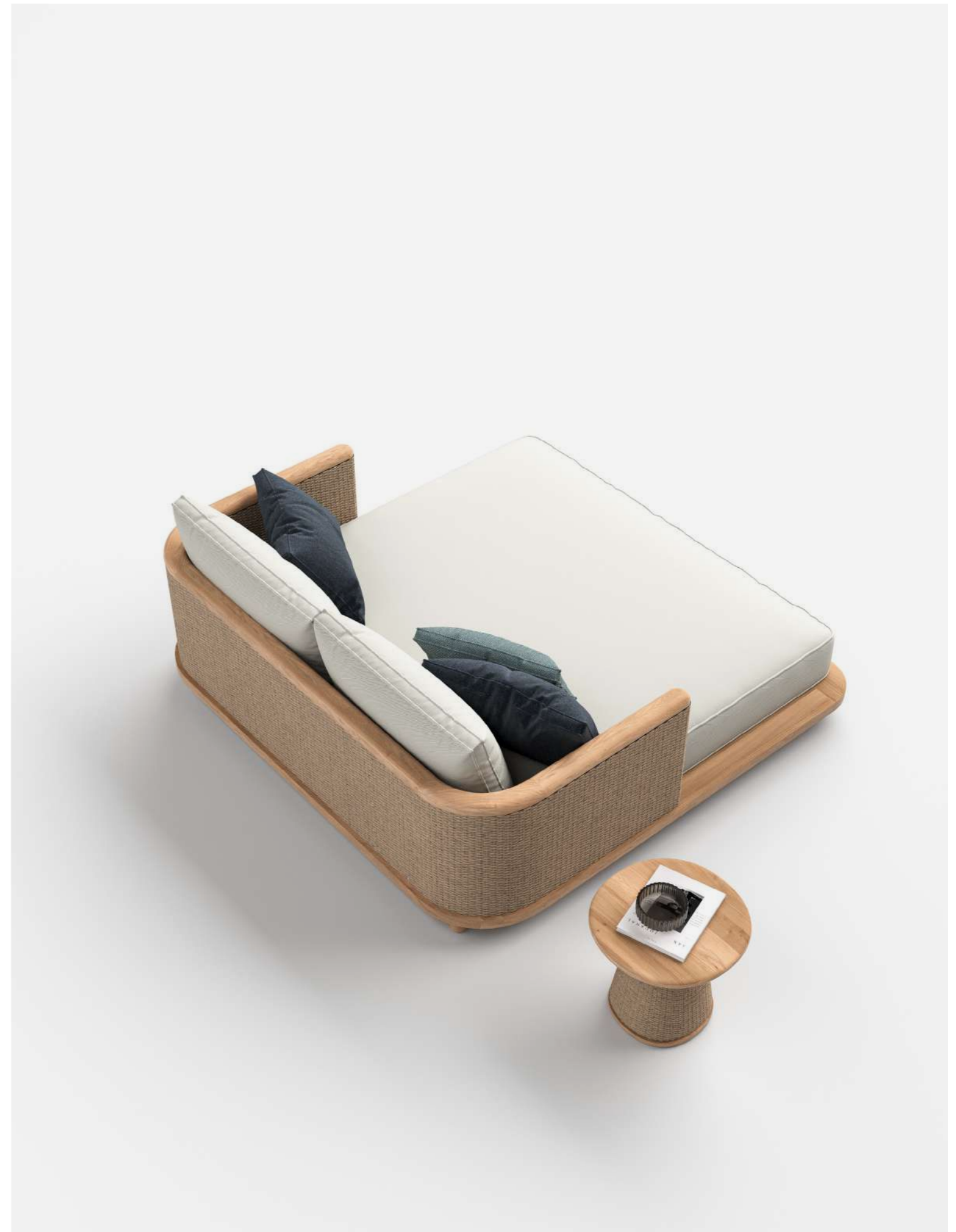



05.

05. Lounger.





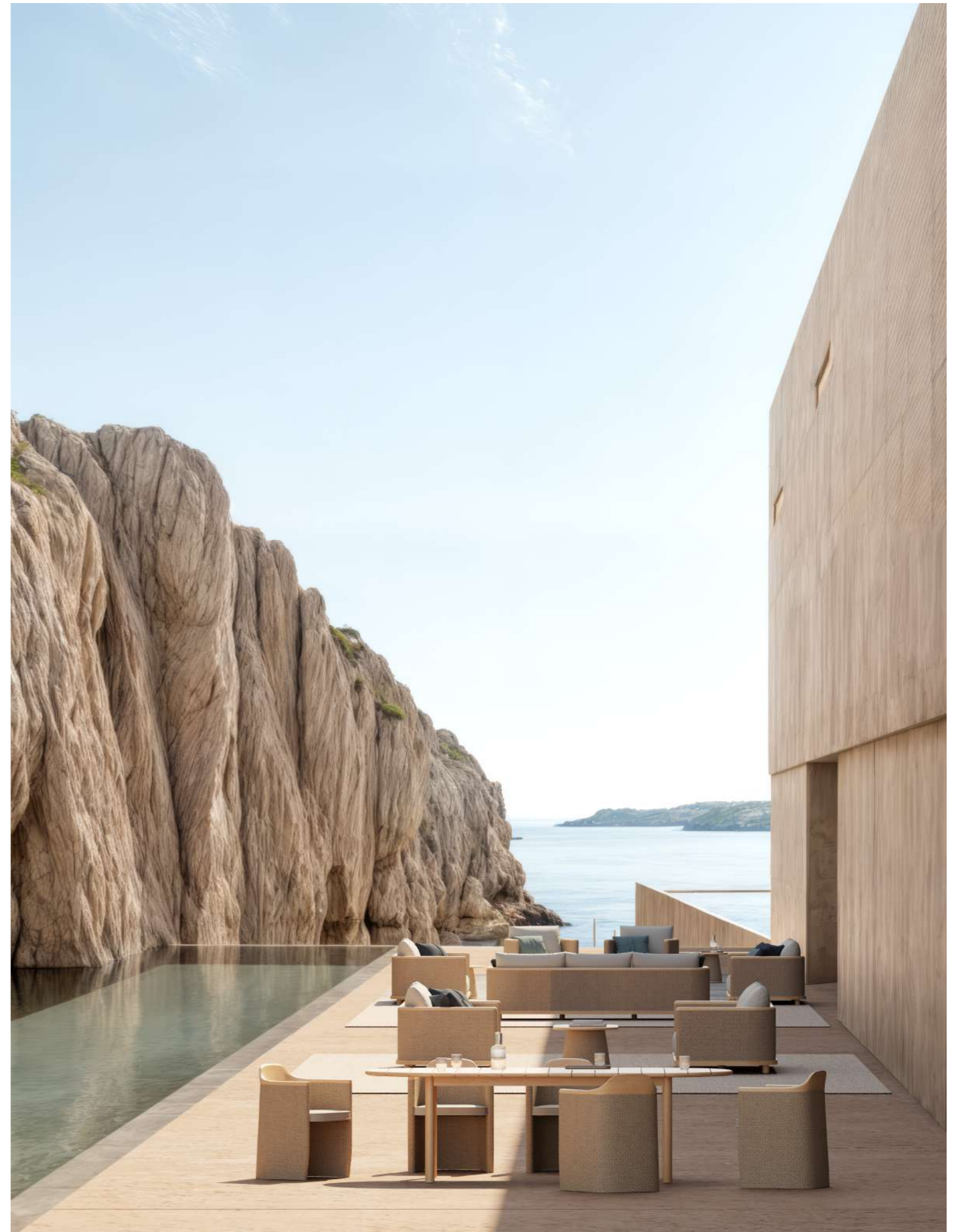



06. Dining armchair.





07.

07. Dining armchair light.



08.

08. Barstool.

09. Round bistro table.

10. Oval dining table.



09.



10.



11.

11. Round dining table.



12.

12. Side table.

13. Oval coffee table.



13.

technical

MATERIALS



Madera de teca
Teak wood



Fibra Fiber
Twisted 20 mm Banana

[24321] ARMCHAIR

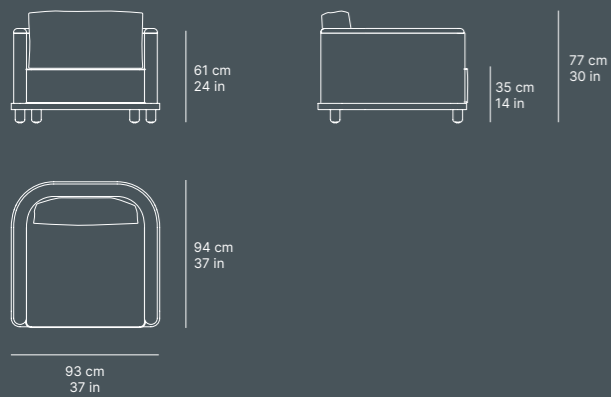

[24322] LOVESEAT

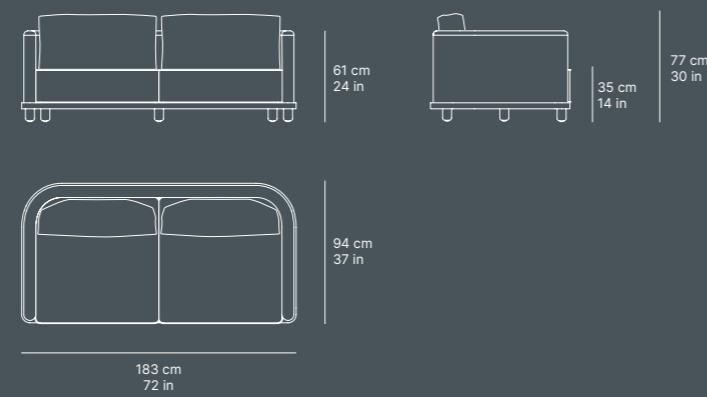

[24326] DAYBED

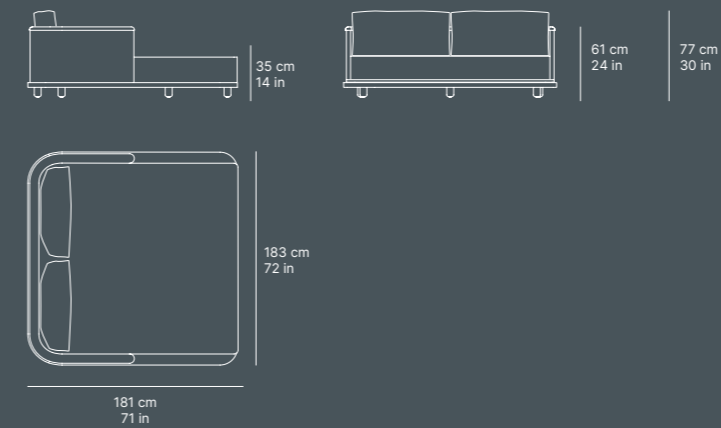

[24320] DINING ARMCHAIR

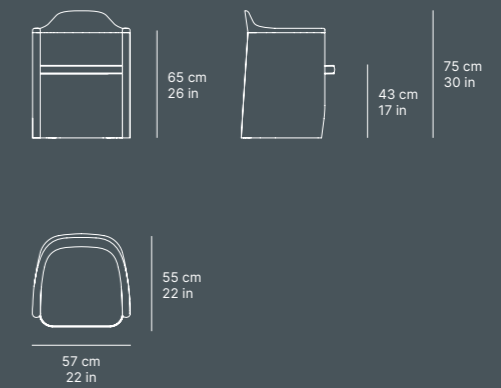

[24323] SOFA

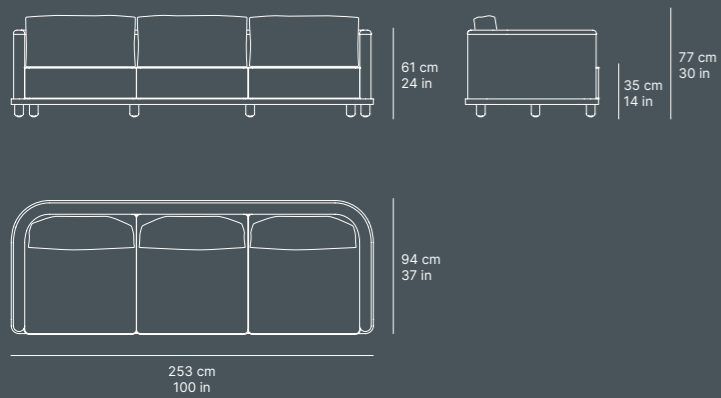

[24328] LOUNGER

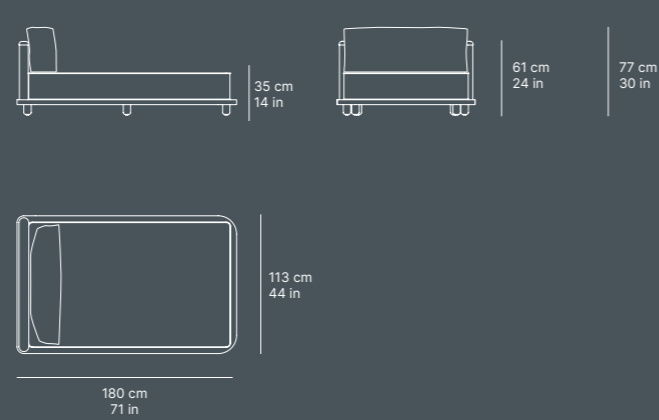

[24332] DINING ARMCHAIR LIGHT

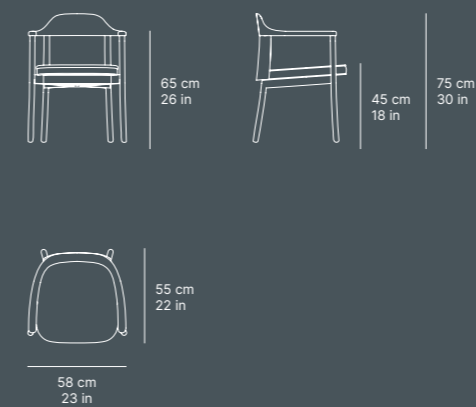

[24329] BARSTOOL

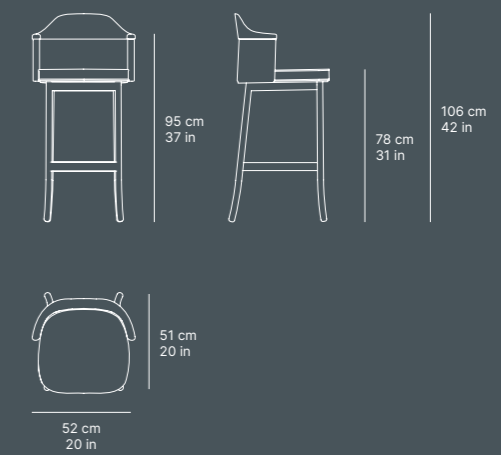

technical

MATERIALS



Madera de teca
Teak wood



Fibra Fiber
Twisted 20 mm Banana

[24331] OVAL DINING TABLE

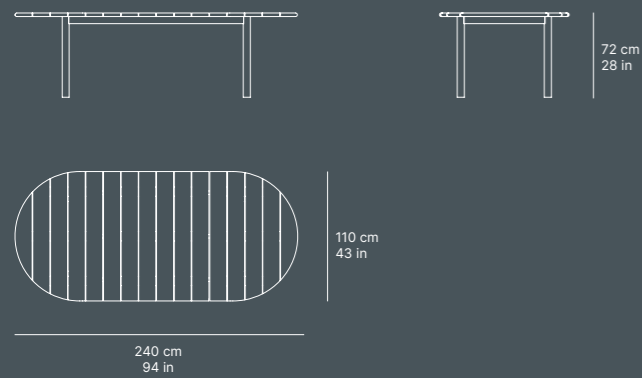

[24327] ROUND DINING TABLE

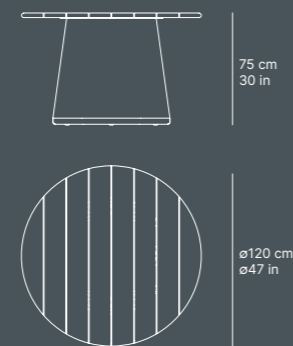

[24325] SIDE TABLE

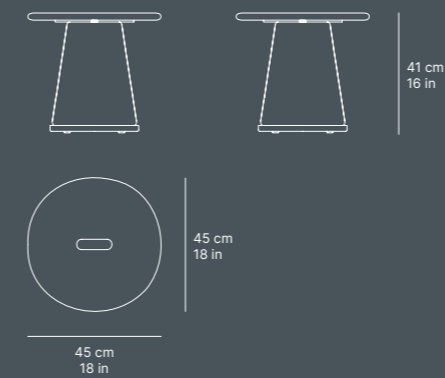

[24324] COFFEE TABLE

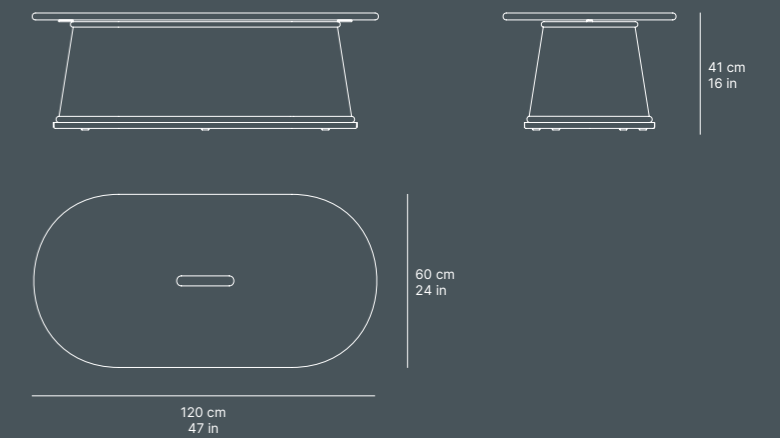

[24330] ROUND BISTRO TABLE

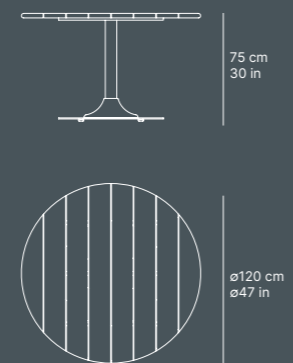

lacus collection by santiago sevillano

Lacus es el resultado de la elegancia contemporánea y la inspiración natural de la laguna de la Albufera. El gesto del respaldo aporta un toque singular y divertido sin comprometer la durabilidad y resistencia de la estructura. La combinación de metal lacado, la teca y el tapizado crea un contraste visualmente atractivo que resalta la belleza y la elegancia de cada pieza siendo una invitación constante a la relajación.

Lacus is the result of contemporary elegance and the natural inspiration of Albufera lagoon. The gesture of the backrest provides a unique and fun touch without compromising the durability and resistance of the structure. The combination of lacquered metal, teak and upholstery creates a visually attractive contrast that highlights the beauty and elegance of each piece, being a constant invitation to relaxation.

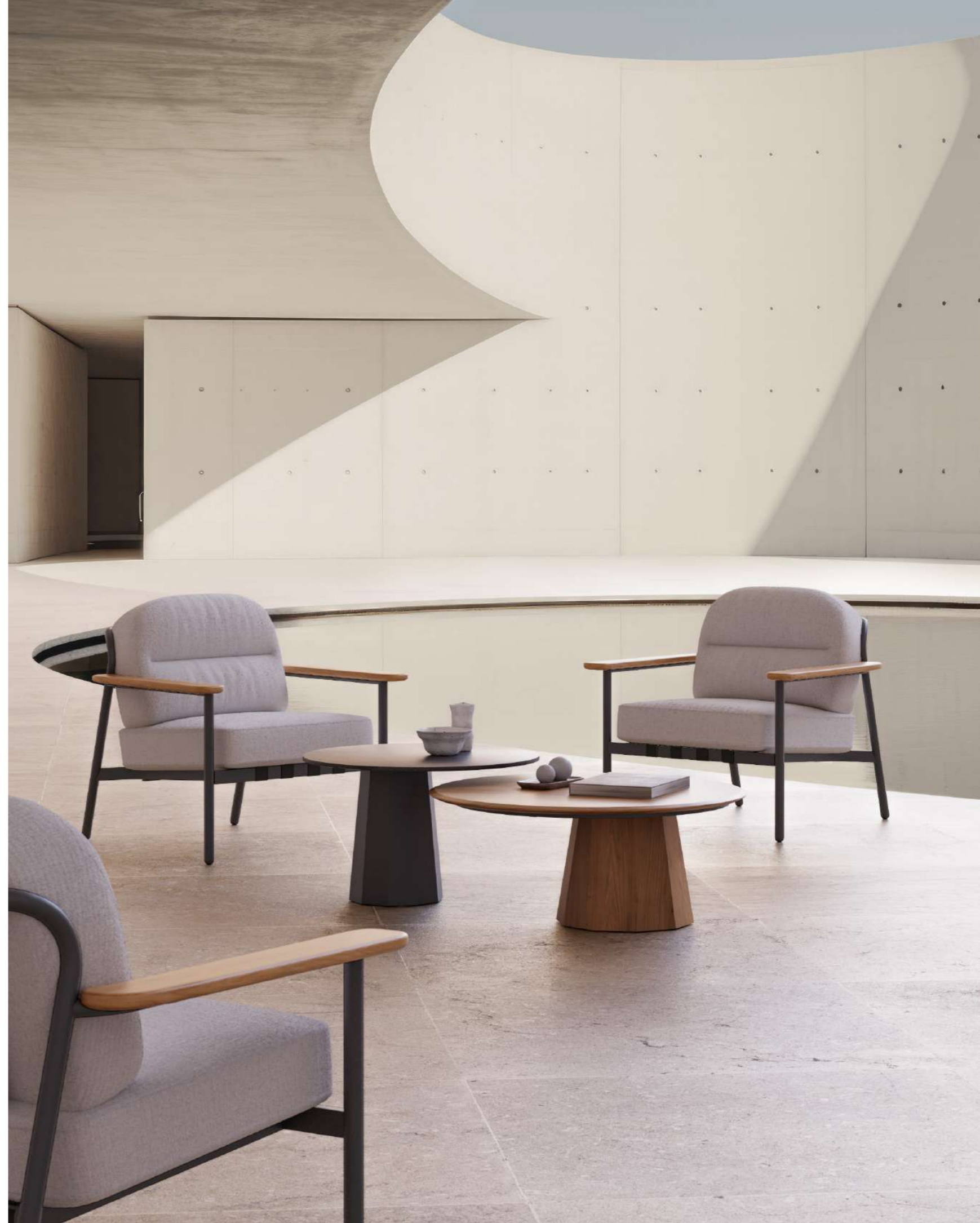





01.



02.



03.

01. Armchair.

02. Loveseat.

03. Sofa.







diseñador
designer

santiago
sevillano



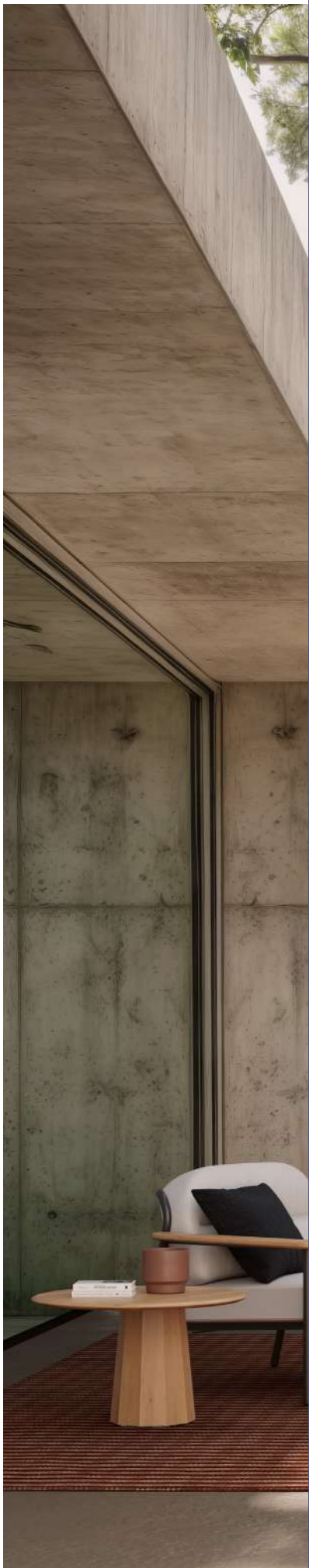

Santiago Sevillano es un estudio internacional situado en Valencia. Su versatilidad a la hora de diseñar les ha permitido estar presentes en diferentes sectores dentro del mundo del diseño. Enfocados en diseños atemporales, buscan soluciones eficaces que se adapten al usuario, apostando por la ergonomía, la sostenibilidad y la funcionalidad. Santiago Sevillano Studio consigue hacer llegar el diseño mediterráneo a todo el mundo.

Santiago Sevillano is an international studio located in Valencia. Their versatility when designing has allowed them to be present in different sectors within the world of design. Focused on timeless designs, they look for effective solutions that adapt to the user, focusing on ergonomics, sustainability and functionality. Santiago Sevillano Studio manages to bring Mediterranean design to the whole world.



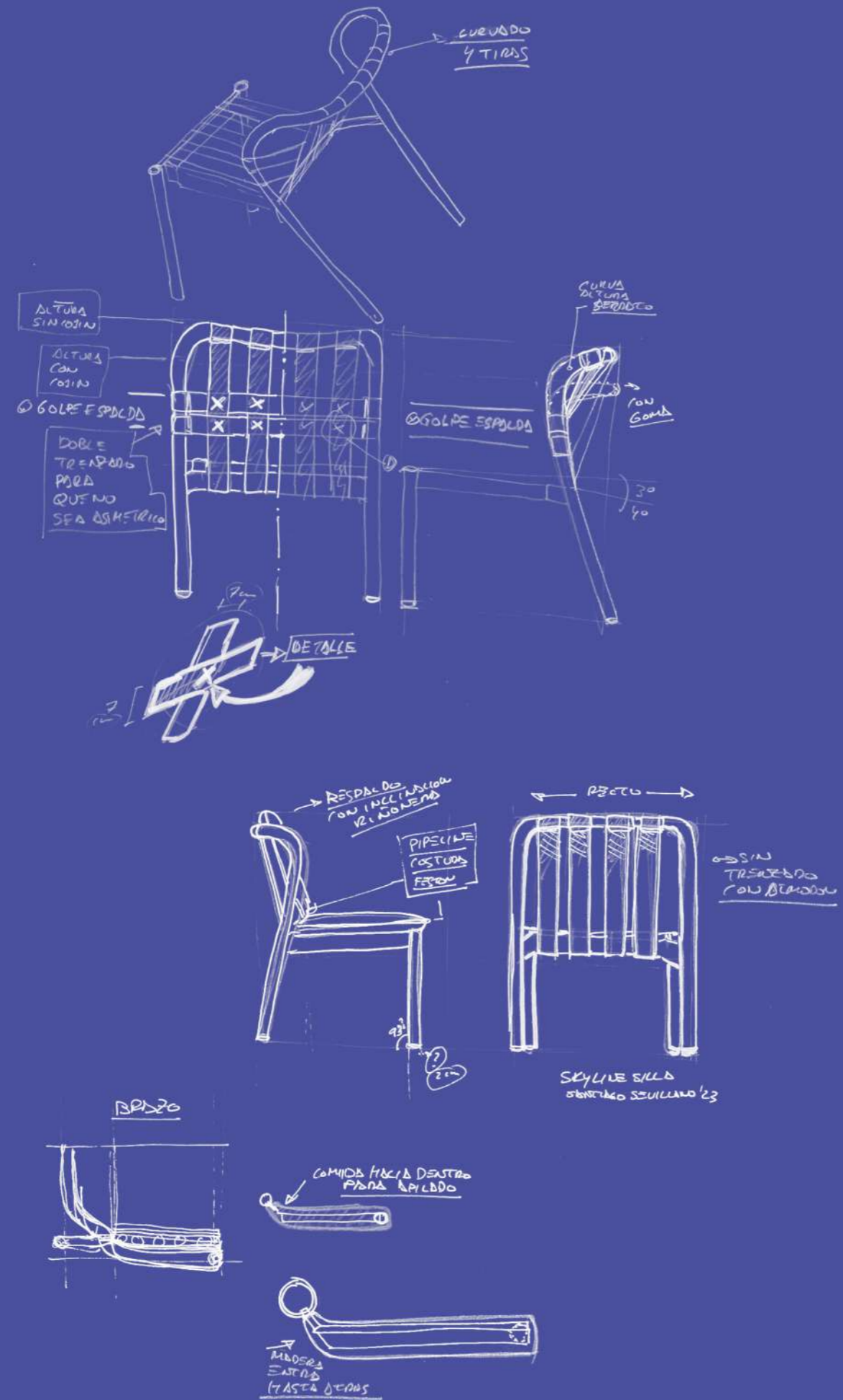
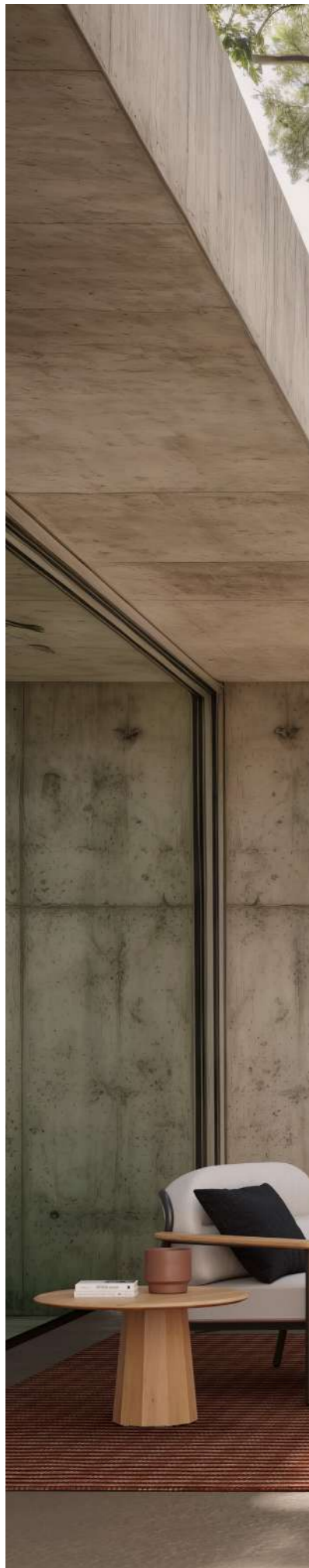



04. Lounger with wheels.



04.

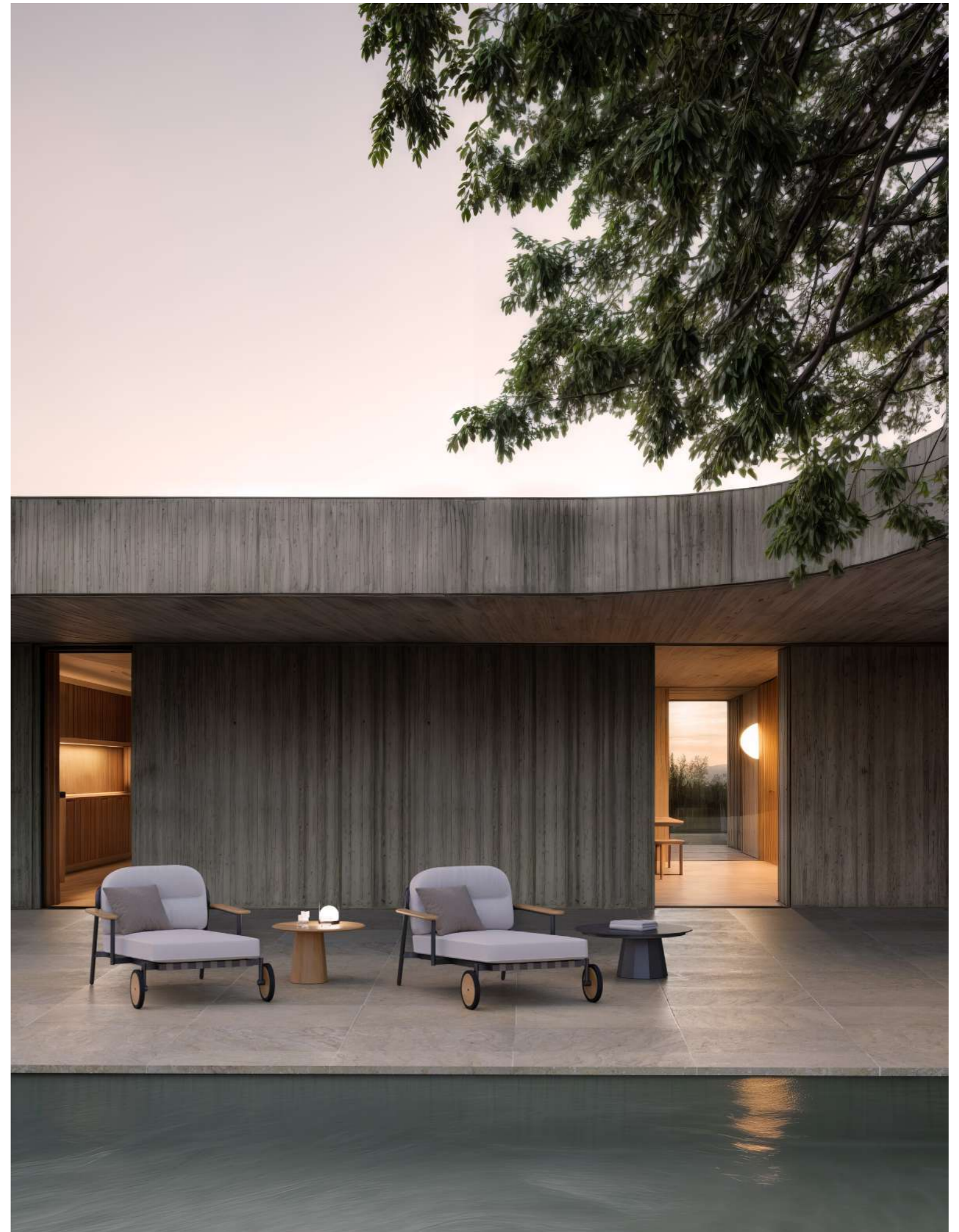



05.



06.

05. Dining armchair.

06. Dining table 220.

07. Dining table 220.



07.





08.



09.

08. Dining table 130.

09. Dining table 130.





10.



10. Barstool.



11.



12.

11. Coffee table low.

12. Coffee table low.

13. Coffee table high.

14. Coffee table high.



13.



14.

technical

MATERIALS



Madera de teca
Teak wood



Aluminio Aluminium
Carbon Matte



Cuerda Rope
Beige Strap

[24349] BALCONY CLUB ARMCHAIR

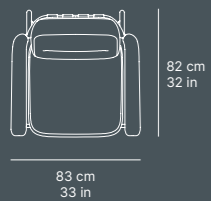

[24351] ARMCHAIR

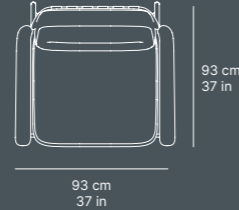

[24356] LOUNGER WITH WHEELS

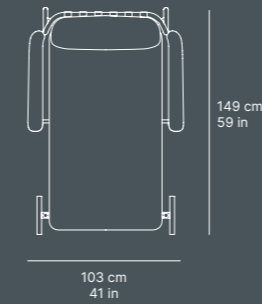
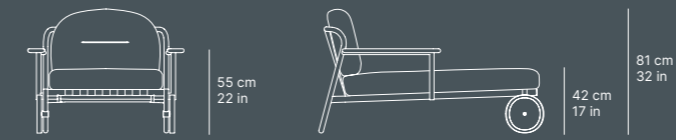

[24350] DINING ARMCHAIR

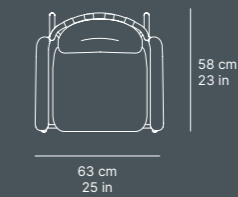

[24352] LOVESEAT

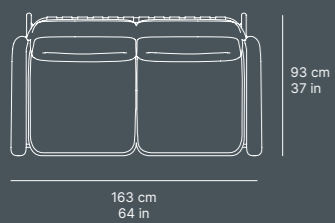

[24353] SOFA

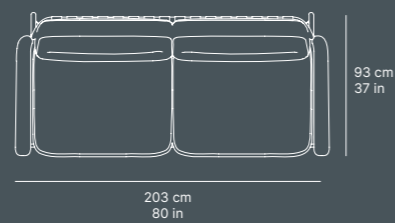

[24359] BARSTOOL

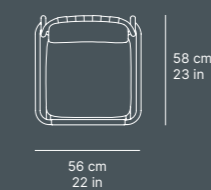
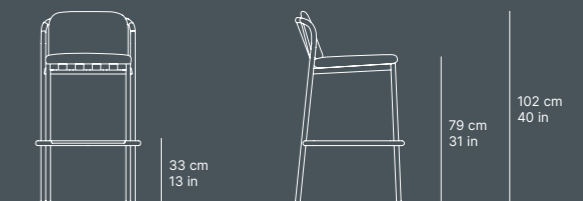

technical

MATERIALS



Madera de teca
Teak wood



Aluminio Aluminium
Carbon Matte



Cuerda Rope
Beige Strap

[24357] DINING TABLE 220

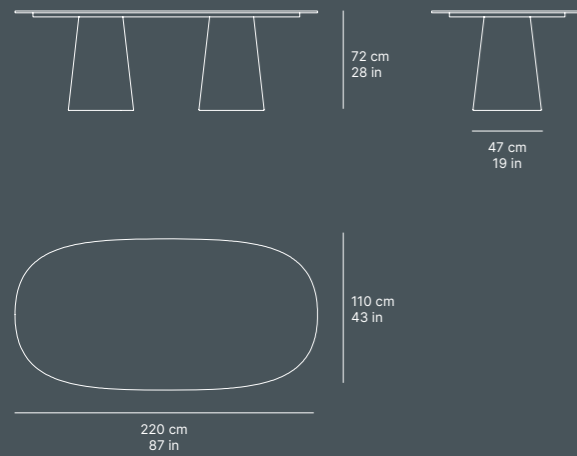

[24358] DINING TABLE 130

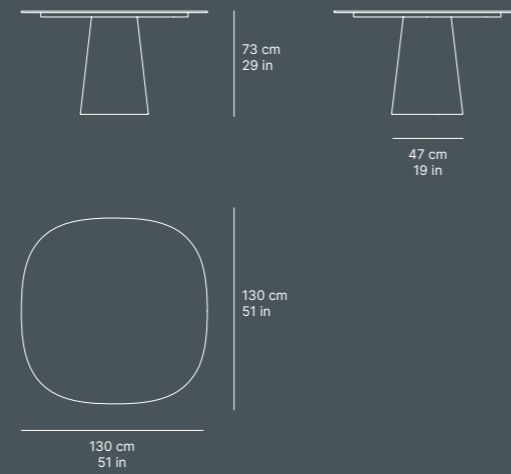

[24355] COFFEE TABLE HIGH

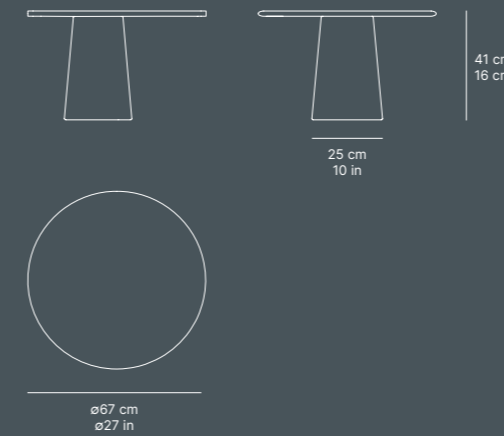

[24354] COFFEE TABLE LOW

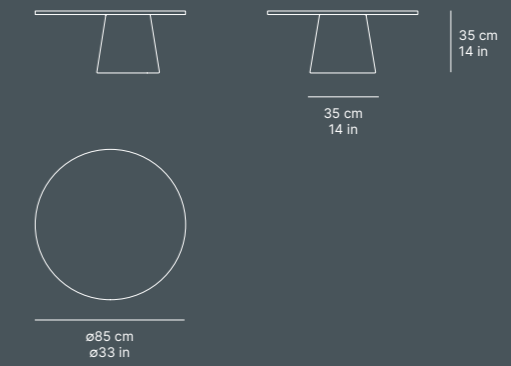

lenis collection by robin hapelt

Lenis pretende romper con los esquemas convencionales de teca y cuerda, infundiendo un toque único a estilos de muebles de teca ya explorados. El resultado es una colección contemporánea inspirada en la forma de una gota de agua, que combina redondez y nitidez. Este diseño minimiza el uso de teca a la vez que introduce un toque étnico que le confiere el fuerte carácter a la colección.

Lenis aims to break away from conventional teak and rope schemes, infusing a unique touch to already explored teak furniture styles. The result is a contemporary collection inspired by the shape of a drop of water, which combines roundness and sharpness. This design minimizes the use of teak while introducing an ethnic touch that gives the collection a strong character.







01.



02.



03.

01. Sofa.

02. Armchair.

03. Loveseat.



01.

diseñador
designer

robin hapelt



03.



Robin Hapelt tiene sus raíces en Alemania y Suiza, pero vive y trabaja la mayor parte del tiempo en el sudeste asiático. “Desde mi primera estancia, el ratán me ha fascinado, las posibilidades que ofrece este material, así como el procesamiento artesanal que como europeo desconocía”. Ambos países influyen en él: “Vida urbana con muchas influencias modernas en Alemania y artesanía y tradición en Suiza”.

Hemos comprendido que es importante desarrollar todo en armonía con la naturaleza. La clave es ‘cradle to cradle’ (de la cuna a la cuna), utilizando materiales que no explotan los recursos de nuestra Tierra ni contribuyen a su contaminación.

Robin Hapelt has his roots in Germany and Switzerland, but lives and works most of the time in Southeast Asia. “Since my first stay, rattan has fascinated me, along with the possibilities this material offers, as well as the craftsmanship, which was unknown to me as a European in this form,” says the German-Swiss designer. Both countries influence him: “Urban life with many modern influences in Germany and craftsmanship and tradition in Switzerland.”

We have understood that it is important to develop everything in harmony with nature. The keyword is ‘cradle to cradle,’ using materials that neither exploit the resources of our Earth nor contribute to its pollution.



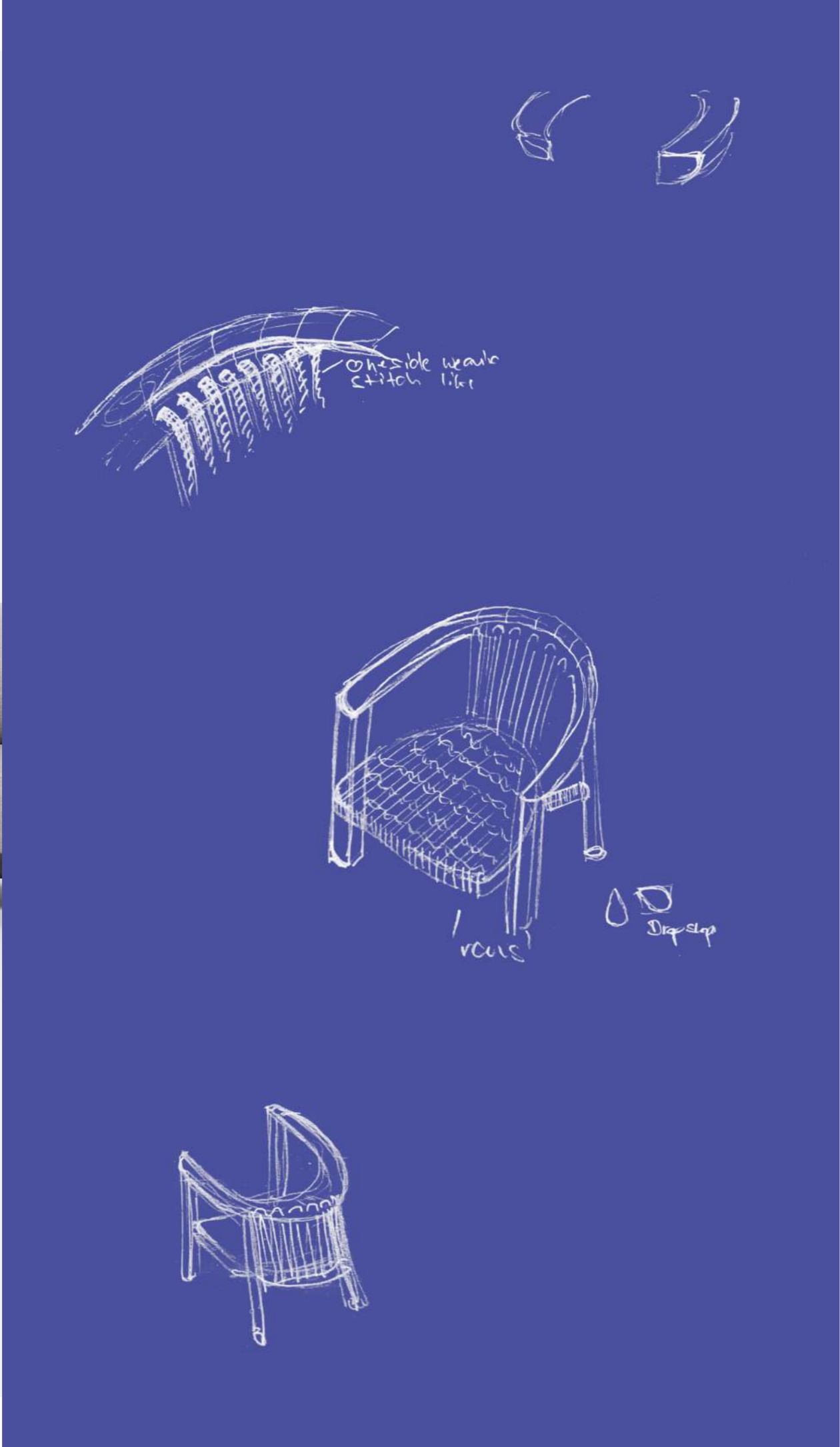

02.



03.

01. Sofa.

02. Armchair.

03. Loveseat.





04. Daybed.





05.

05. Dining armchair.



06.



07.

06. Dining table 250.

07. Dining table 200.





08.

08. Coffee table.

09. Side table.



09.

technical

MATERIALS



Madera de teca
Teak wood



Cuerda Rope
C/168

[24341] ARMCHAIR

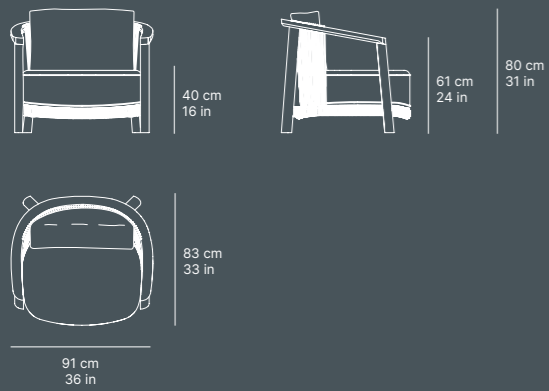

[24342] LOVESEAT

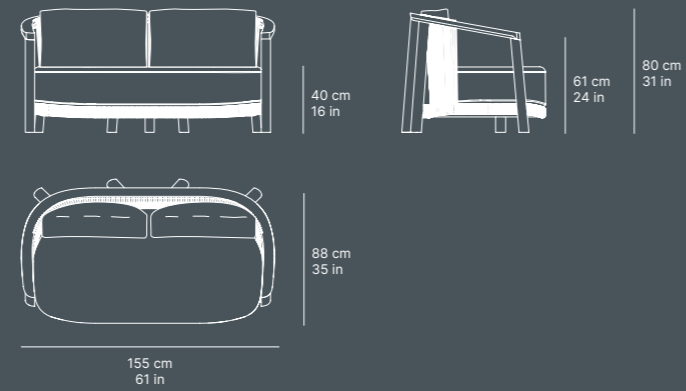

[24346] DAYBED

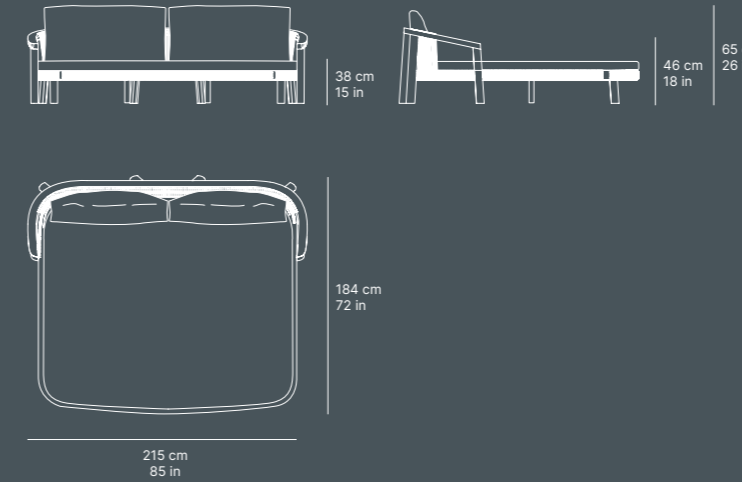

[24340] DINING ARMCHAIR

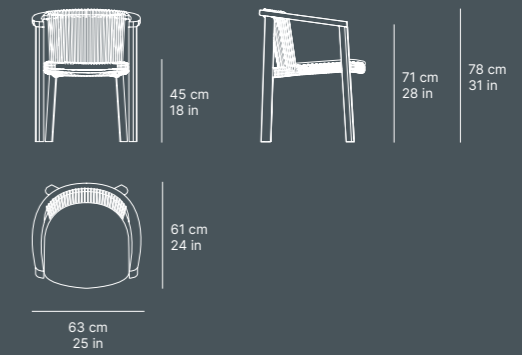

[24343] SOFA

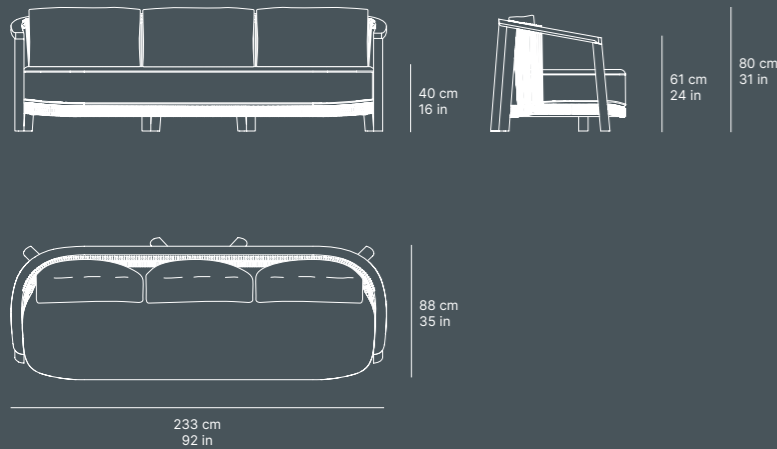

technical

MATERIALS



Madera de teca
Teak wood



Cuerda Rope
C/168

[24347.01] DINING TABLE 250



[24347] DINING TABLE 200



[24345] SIDE TABLE

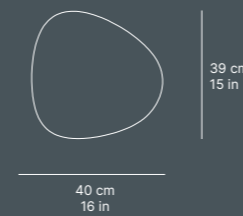

[24344] COFFEE TABLE

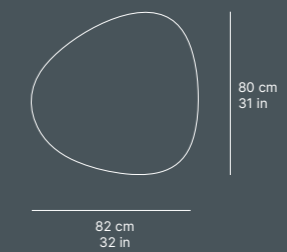

ventus collection by belén burguete

Ventus tiene una estética completamente contemporánea, es una colección sutil, de estilo mediterráneo que aporta firmeza gracias al volumen de su base tapizada. Un diseño de líneas depuradas y limpias, sin adornos innecesarios. Su simplicidad estructural lo hace capaz de adaptarse a cualquier espacio exterior.

Ventus has a completely contemporary aesthetic, it is a subtle, Mediterranean-style collection that provides firmness thanks to the volume of its upholstered base. A design with refined and clean lines, without unnecessary ornaments. Its structural simplicity makes it capable of adapting to any outdoor space.







01.



02.

01. Square daybed with canopy.

02. Double lounger.



03.

03. Single lounger.







04.

04. Reclining lounge with wheels.

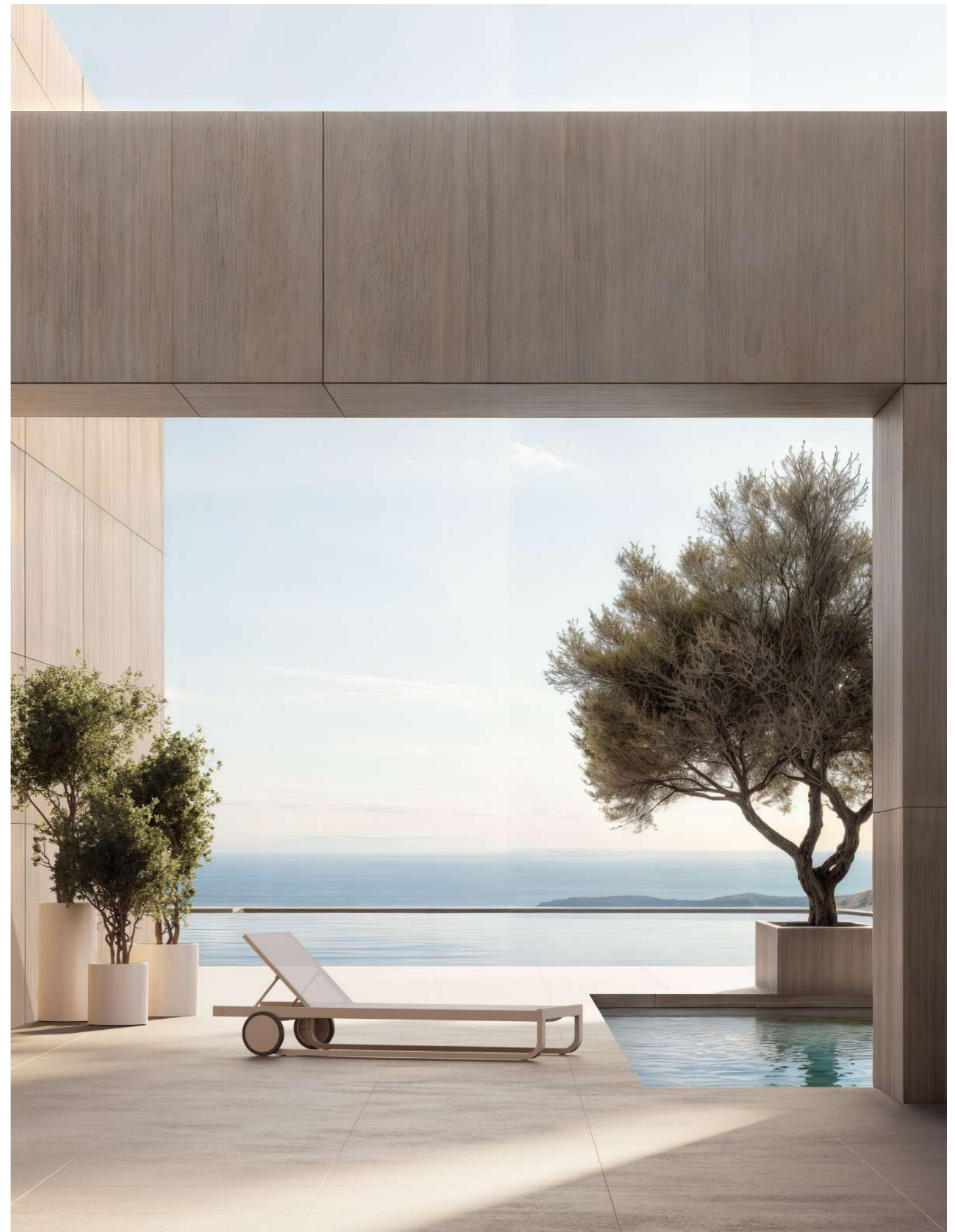



05.



06.



07.

05. Planter small.

06. Planter medium.

07. Planter large.

diseñadora
designer



05.



07.

05. Planter small.

06. Planter medium.

07. Planter large.

belén
burguete

05. Planter small.

06. Planter medium.

07. Planter large.



Apasionada por el diseño y el entorno, intento crear conceptos innovadores y frescos. Parto de una idea que seduzca al cliente y la moldeo dependiendo de su función y estética. Cada producto que diseño es diferente en su concepto y en su forma, aportando nuevos materiales que den forma y color al diseño para que sea funcional y fácil de entender.

Passionate about design and the environment, I try to create innovative and fresh concepts. I start with an idea that seduces the client and I shape it depending on its function and aesthetics. Each product I design is different in its concept and form, providing new materials that give shape and color to the design so that it is functional and easy to understand.



07.

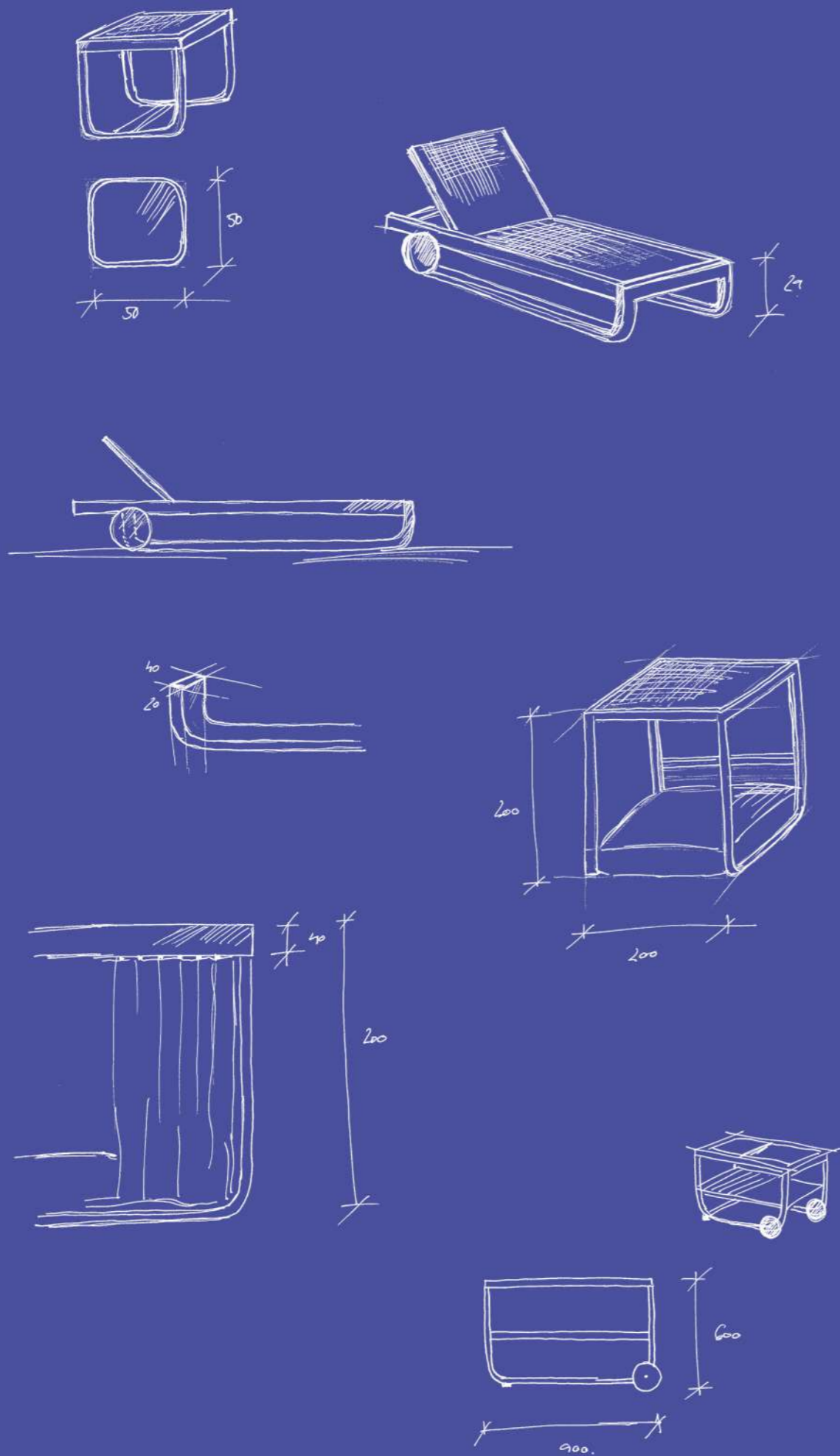

05. Planter small.

06. Planter medium.

07. Planter large.



06.



07.



08.

08. Trolley.





09.

09. Round auxiliar table.



10.

10. Square auxiliar table.

technical

MATERIALS



Aluminio *Aluminium*
White Wash

[24376] SQUARE DAYBED WITH CANOPY

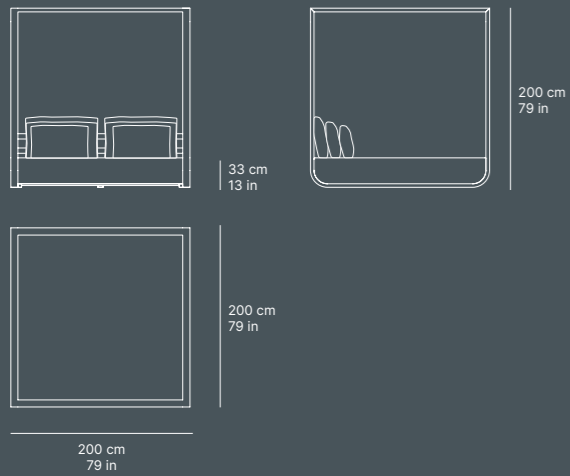

[24379] DOUBLE LOUNGER

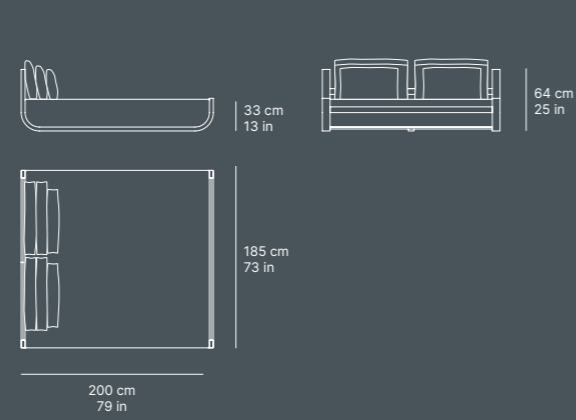

[24370] SQUARE AUXILIAR TABLE

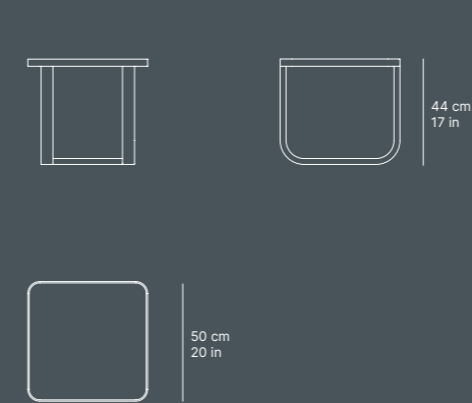

[24371] SQUARE AUXILIAR TABLE

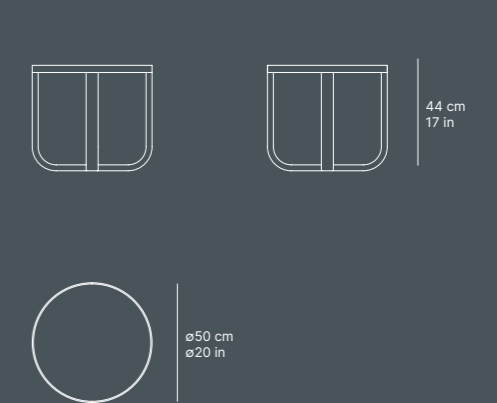

[24378] SINGLE LOUNGER

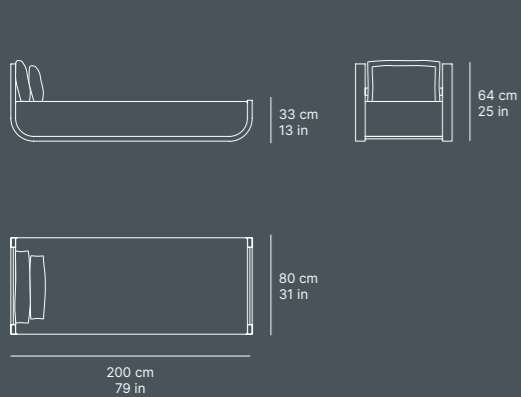

[24377] RECLINING LOUNGE WITH WHEELS

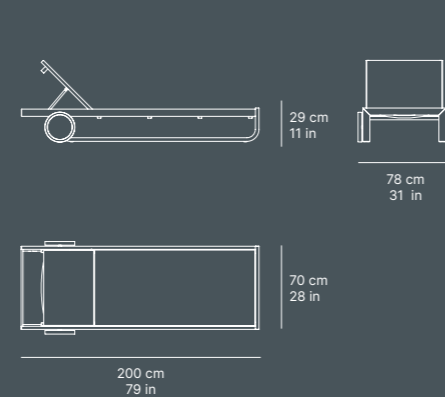

technical

MATERIALS



Aluminio *Aluminium*
White Wash

[24372] PLANTER LARGE

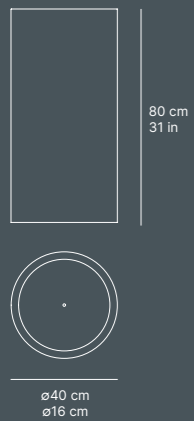

[24373] PLANTER MEDIUM

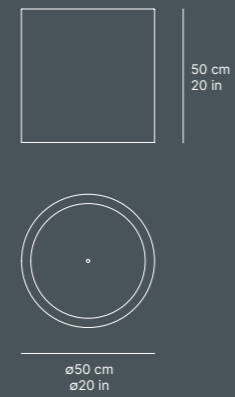

[24374] PLANTER SMALL

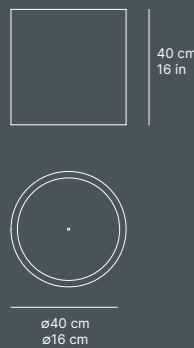

[24375] TROLLEY

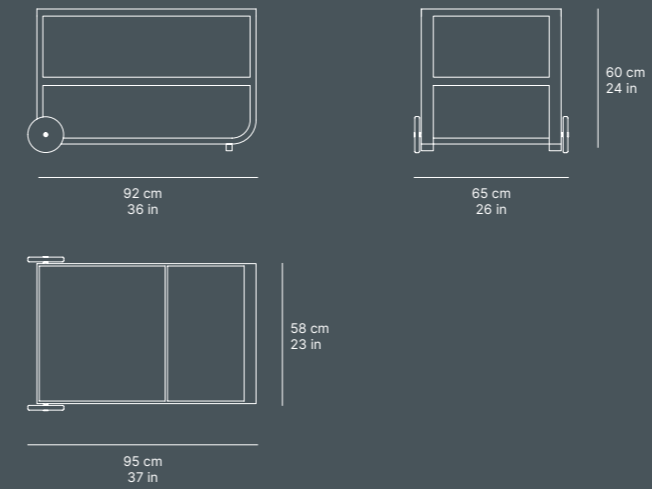

materials

materials

OTTOMAN



20066 Pergamino

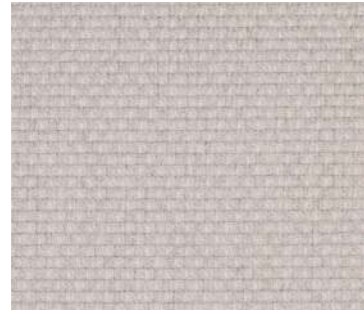

20067 Gris Porcelana

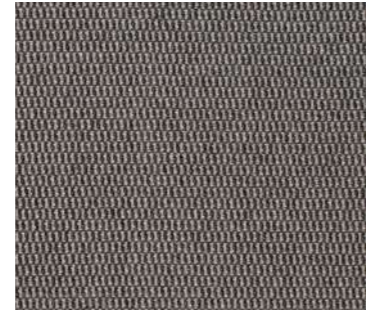

20073 Stone Grey

RITMO



20095 Laguna



20092 Celadon



20093 Umbra

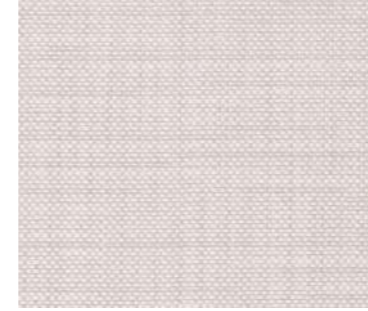

20084 Cream

LISO



20205 Hollin



20203 Umbra



20204 Laguna

fabrics

PANAMA

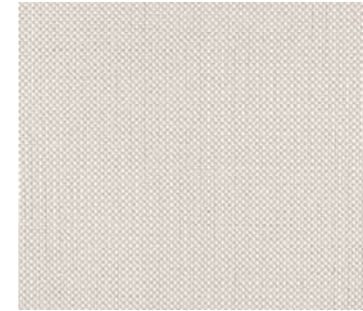

1320 Bone

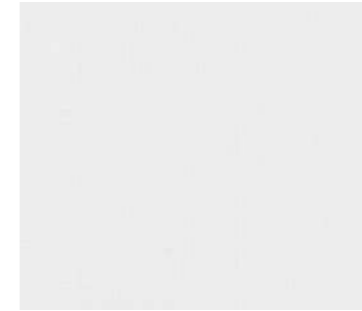

20208 Optik

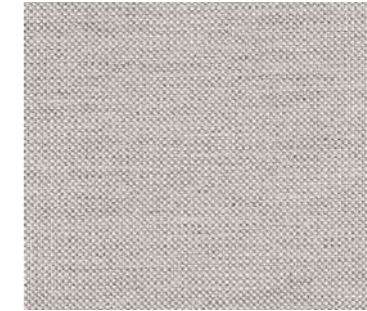

3658 Cloud



8010 Malva



1319 Navy



1322 Marble

BRUMA



1009 Nuez

materials

dekton

Dekton Nacre
Kraftizen



Dekton Nebbia
Pietra Kode



Dekton VK03
Grigio Pietra Kode



VK04 Grafite
Pietra Kode

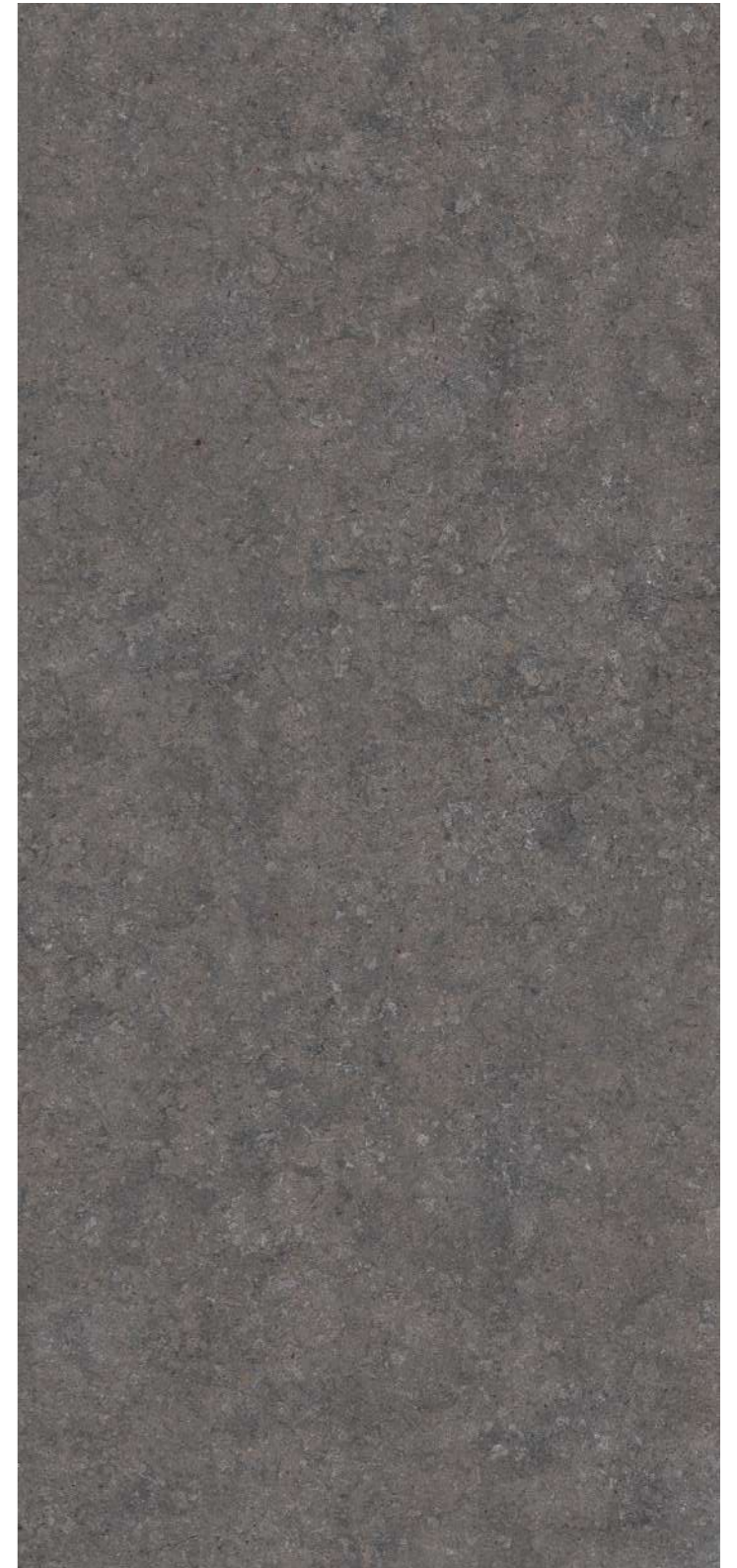

Concept, Art Direction and Visuals
Inmenso Studio

Writing Text
SKLD Studio

Logo Concept
Jiménez De Nalda ®

Copyright 2024 SKLD Studio
All rights reserved

