

SKLD STUDIO

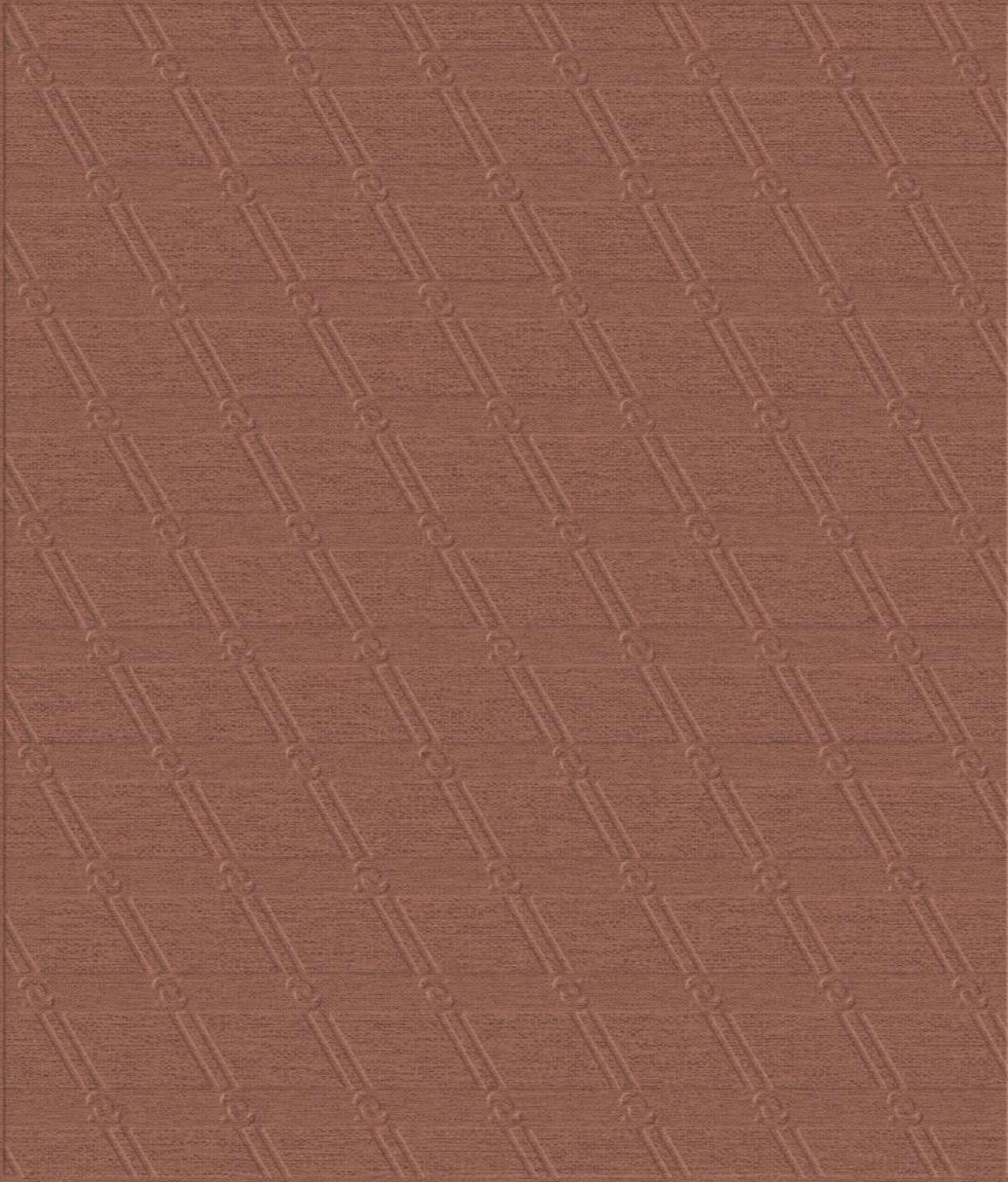

Vol. 1

SKLD STUDIO

by

VOOLCAN
Grupo

Explora el universo de SKLD Studio, donde el diseño cobra vida y la funcionalidad se convierte en arte. Cada colección es una expresión de innovación, creada bajo el estándar de calidad que define a Voolcan Grupo.

Explore the universe of SKLD Studio, where design comes to life and functionality becomes art. Each collection is an expression of innovation, created under the quality standard defined by Voolcan Grupo.



En SKLD Studio, la excelencia no es un estándar, sino una filosofía. Fusionamos materiales tradicionales con técnicas de vanguardia para dar vida a piezas únicas y atemporales. Cada componente es cuidadosamente seleccionado para garantizar una estética sofisticada, una alta calidad y una experiencia de uso excepcional.

En este segundo volumen, hemos ampliado nuestras colaboraciones con los mejores profesionales del sector, dando vida a cinco nuevas colecciones exclusivas. Cada pieza es el resultado de la fusión entre un diseño excepcional y técnicas artesanales aplicadas a materiales industriales. Bienvenido de nuevo a SKLD Studio.

At SKLD Studio, excellence is not just a standard, but a philosophy. We merge traditional materials with cutting-edge techniques to bring unique and timeless pieces to life. Each component is carefully selected to ensure a sophisticated aesthetic, high quality, and an exceptional user experience.

In this second volume, we have expanded our collaborations with the best professionals in the industry, bringing to life five new exclusive collections. Each piece is the result of the fusion between exceptional design and handcrafted techniques applied to industrial materials. Welcome back to SKLD Studio.



index

olma

08

velair

40

koro

60

serra

88

eki

118

materials

136

olma collection by la mamba

Olma es un proyecto que surge de la combinación de ligereza, calidez y confort en exterior, inspirado en la elegante silueta de un remo. Su estructura en madera de teca, resistente y natural, se entrelaza con detalles en cuerda para crear una colección armoniosa de sofás, sillas, mesas y tumbonas. Un diseño envolvente que evoca la fluidez del movimiento en el agua, acompañado de amplios cojines acolchados que invitan al descanso y la desconexión en entornos al aire libre.

Olma is a project that emerges from the combination of lightness, warmth, and outdoor comfort, inspired by the elegant silhouette of an oar. Its structure, made of durable and natural teak wood, is intertwined with rope details to create a harmonious collection of sofas, chairs, tables, and loungers. An enveloping design that evokes the fluidity of movement on the water, accompanied by generous padded cushions that invite relaxation and disconnection in outdoor.







01.

01. Love seat.



02.

02. Sofa.



03.



03. Lounge chair.





04.

04. Daybed.







05. Reclining lounger.





diseñadores
designers

la mamba



La Mamba es un estudio de diseño fundado en 2010 con la visión de crear objetos que trasciendan lo estético para convertirse en experiencias funcionales y emocionales. En La Mamba abordamos el diseño desde una perspectiva armonizada y global, donde la estética, la funcionalidad y la comunicación se entrelazan de manera natural.

Creemos en la funcionalidad sin artificios, en la sensibilidad de los materiales, en la serenidad de las formas y en el equilibrio entre innovación y tradición. Desde la conceptualización hasta la producción, buscamos crear piezas que dialoguen con su entorno y enriquezcan la vida cotidiana.

La Mamba is a design studio founded in 2010 with the vision of creating objects that transcend aesthetics to become functional and emotional experiences. At La Mamba, we approach design from a harmonized and global perspective, where aesthetics, functionality, and communication intertwine naturally.

We believe in functionality without artifices, in the sensitivity of materials, in the serenity of forms, and in the balance between innovation and tradition. From conceptualization to production, we strive to create pieces that engage with their surroundings and enrich everyday life.

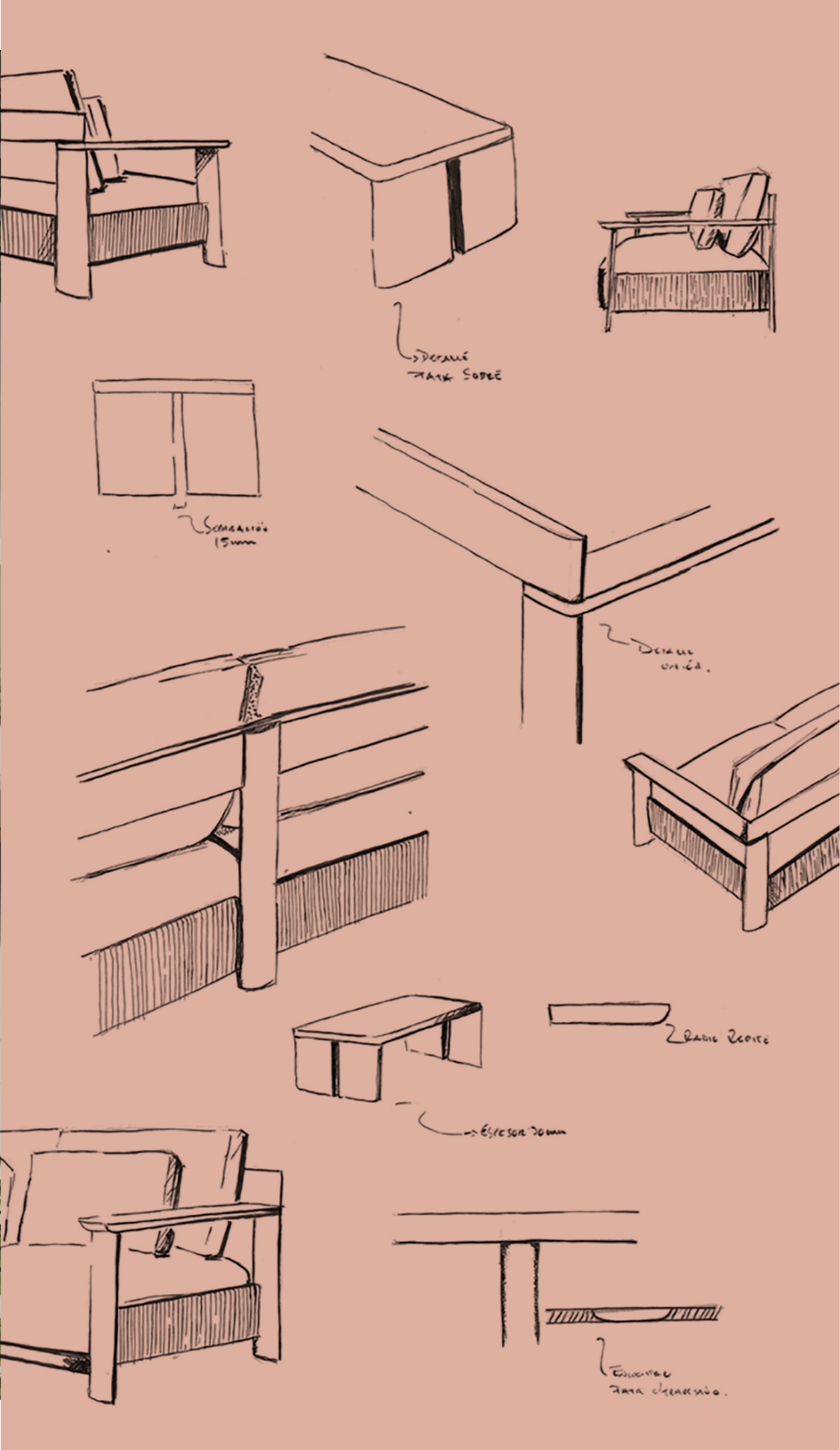





06.



07.

06. Dining chair.

07. Dining armchair.





08. Dining table.



08.



09.



10.

09. Low coffee table.

10. High coffee table.

11. Side table.



11.

technical

MATERIALS



Madera de teca
Teak wood



Cuerda
Rope

[24401] LOUNGE CHAIR

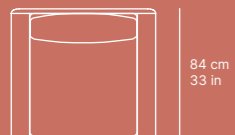
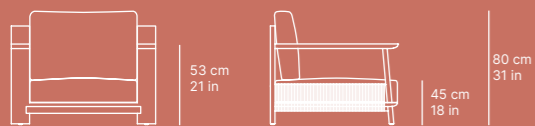

95 cm
37 in

[24402] LOVE SEAT

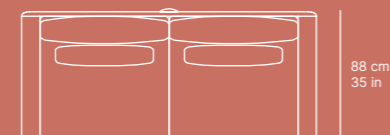
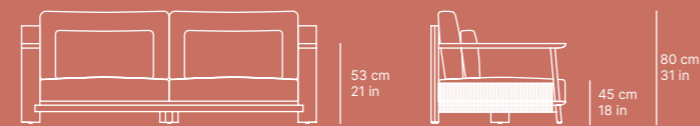

194 cm
76 in

[24408] RECLINING LOUNGER

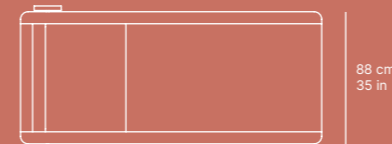

200 cm
79 in

[24406] DAYBED

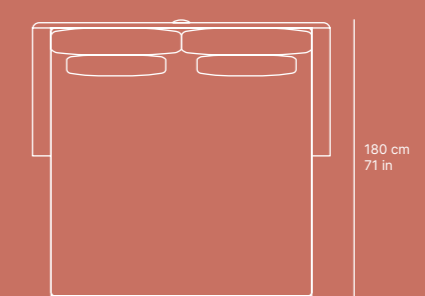
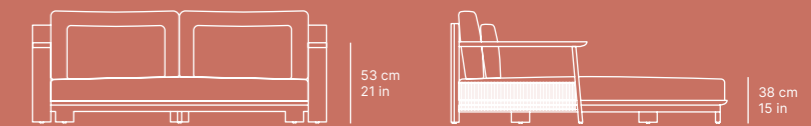

194 cm
76 in

[24403] SOFA

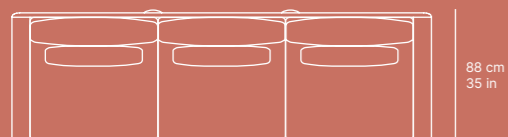

280 cm
110 in

technical

[24409] DINING CHAIR

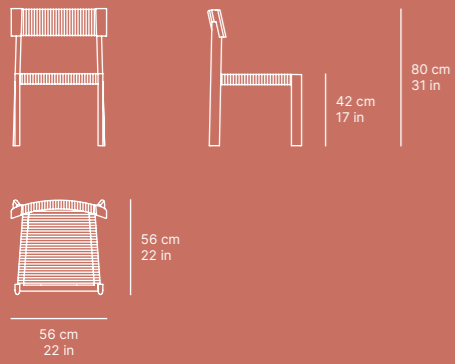

[24400] DINING ARMCHAIR

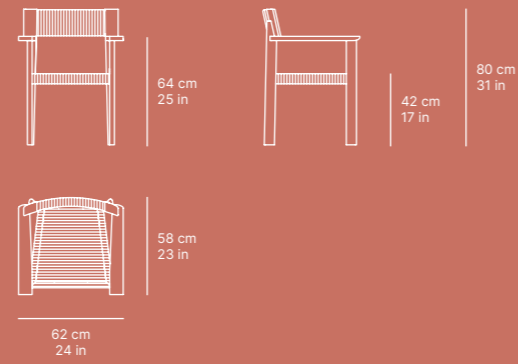

MATERIALS



Madera de teca
Teak wood



Cuerda
Rope

[24407] DINING TABLE

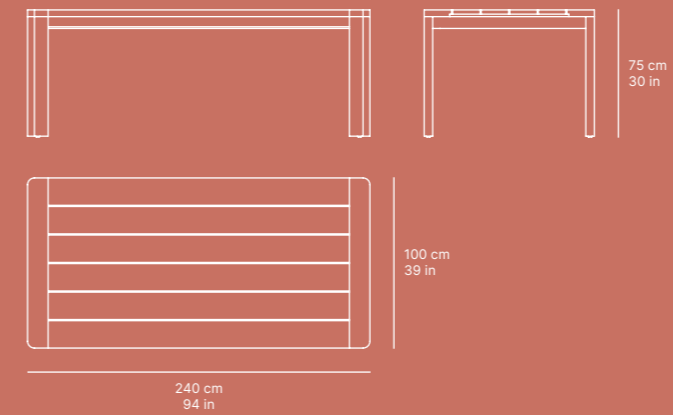

technical

MATERIALS



Madera de teca
Teak wood

[24404] HIGH COFFEE TABLE

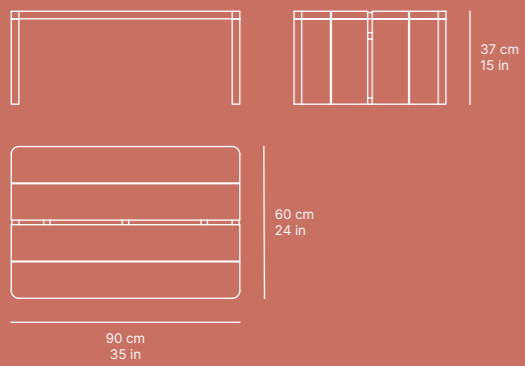

[24404.01] LOW COFFEE TABLE

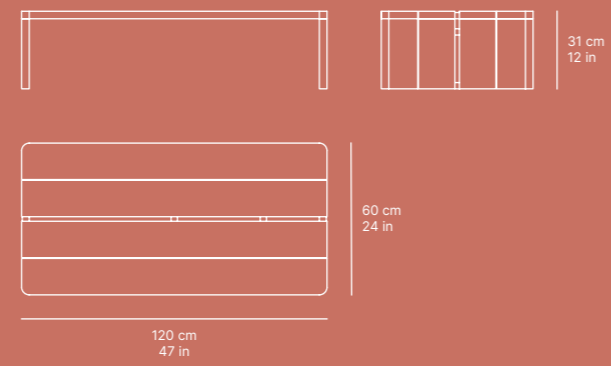

[24405] SIDE TABLE

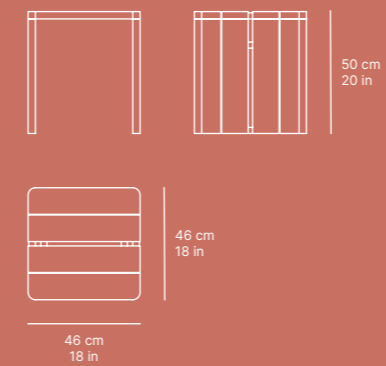

velair collection by alberto lievore

La armonía con el entorno es condición primera en este proyecto. La estructura de madera de teca posee una gestualidad tal que sin los cojines para su uso, pueda integrarse en un entorno natural durante todas las estaciones. La familia se compone de sofás, butacas y chaise longues, para dar respuesta a las más diversas situaciones y usos.

Harmony with the environment is the first condition in this project. The teak wood structure has such a gesture that without the cushions for its use, it can be integrated in a natural environment during all seasons. The family is composed of sofas, armchairs and chaise longues, to respond to the most diverse situations and uses.







01.

01. Lounge chair.

diseñadores
designers



02.

alberto
lievore &
asociados



El estudio, reconocido en 1999 con el Premio Nacional de Diseño por su trayectoria profesional, se especializa en el sector del mobiliario donde adquiere notoriedad tanto en América y Asia, como en Europa, especialmente en Italia, en el desarrollo de producto, consultoría estratégica y comunicación integral; ganando entre otros, el Compasso D'Oro en 2016.

En esta colección han colaborado junto a Alberto Lievore, Aurélien Hary, Francisco Mazo, Fran Ruiz y Cecilia Costa.

The studio, awarded the National Design Prize in 1999 for its professional career, specializes in the furniture sector, gaining recognition in America, Asia, and Europe —particularly in Italy— for product development, strategic consulting, and comprehensive communication. Among other accolades, it won the Compasso D'Oro in 2016.

For this collection, they collaborated with Alberto Lievore, Aurélien Hary, Francisco Mazo, Fran Ruiz, and Cecilia Costa.

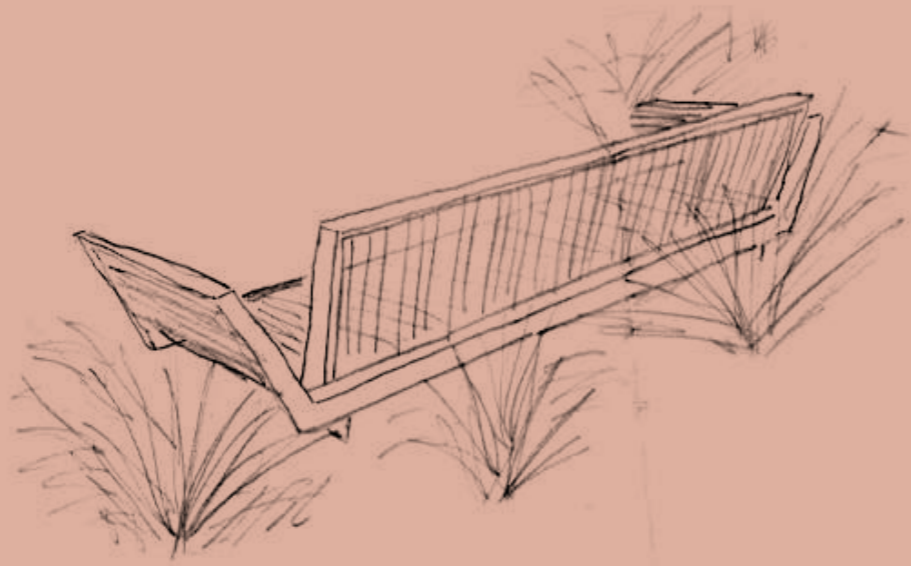
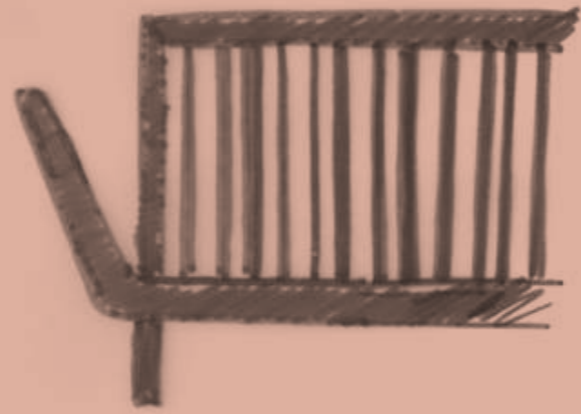

02. Sofa.





03.

03. Reclining lounger.





04.

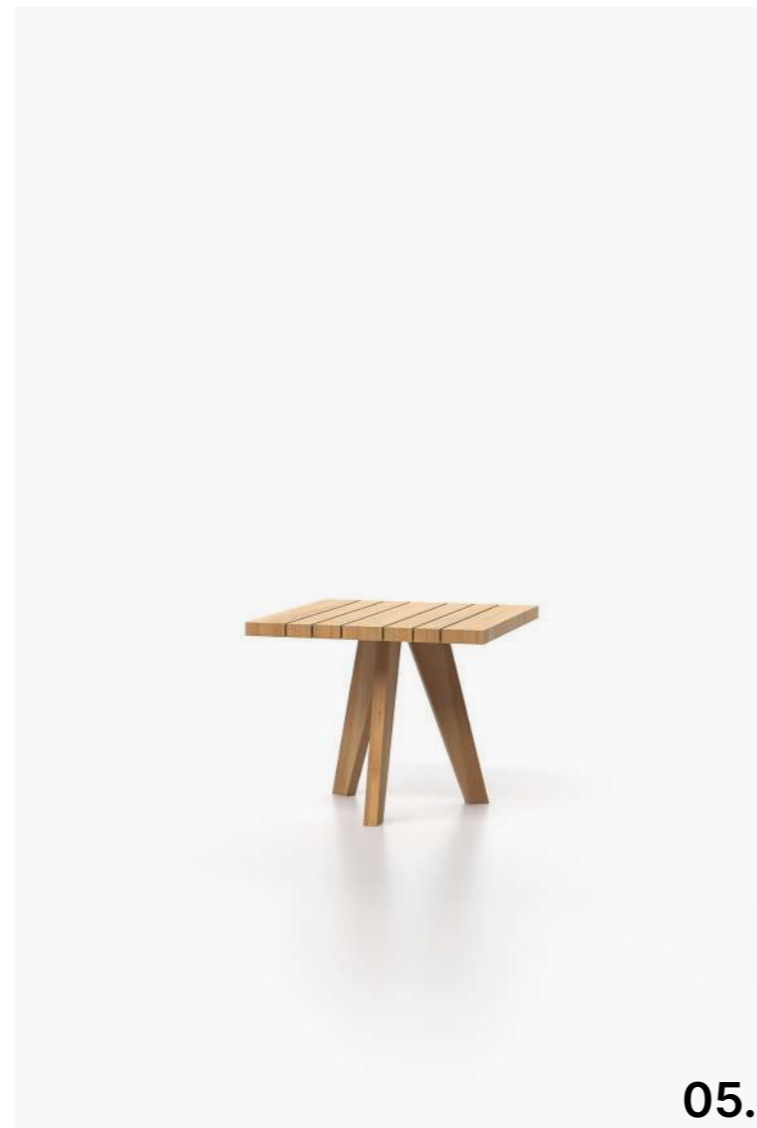

05.

04. Side table D60.

05. Side table 54x54.





06.



07.

06. Coffee table D135.

07. Coffee table D90.

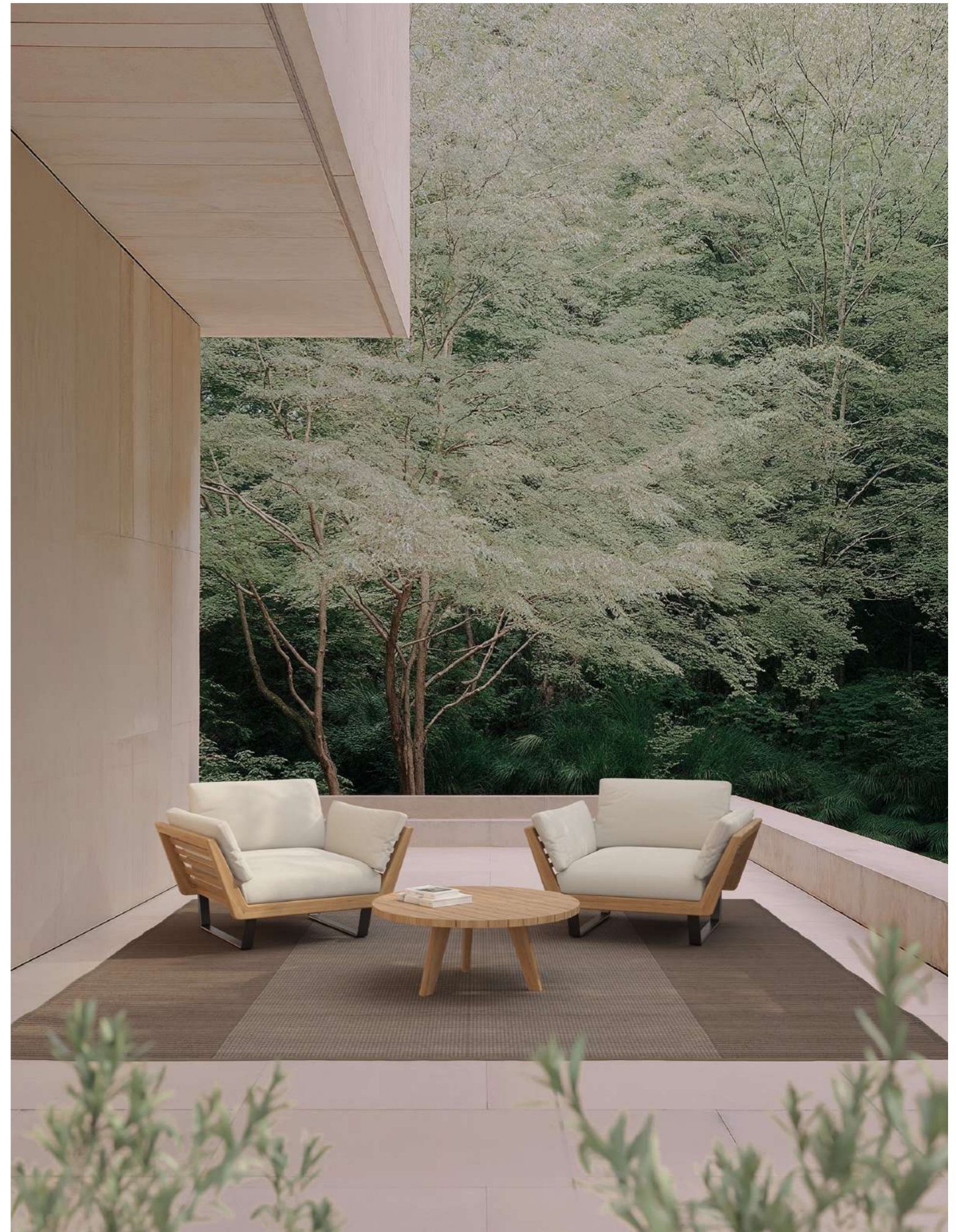

technical

MATERIALS



Madera de teca
Teak wood

[24391] LONGUE CHAIR

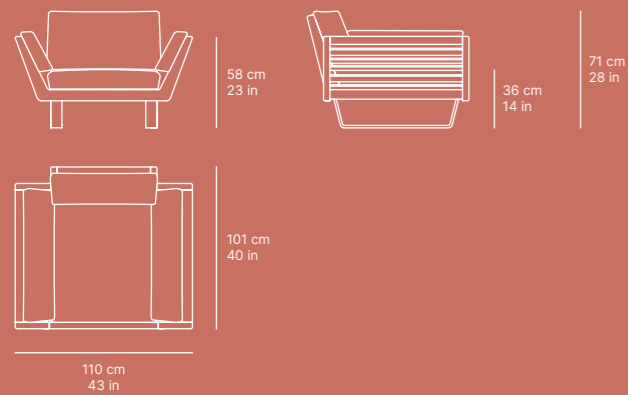

[24393] SOFA

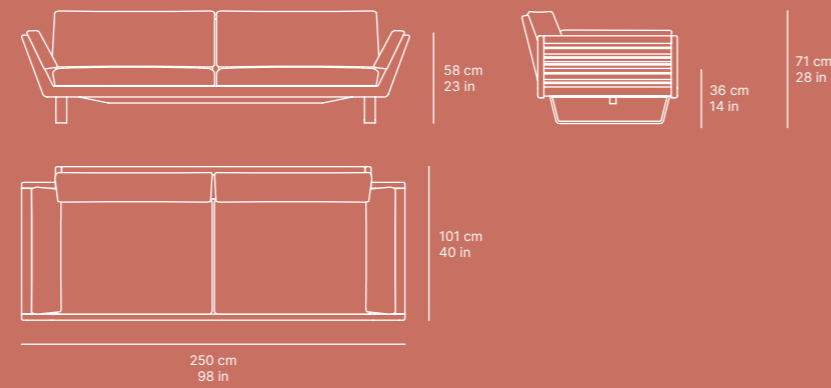

[24394.XX] COFFEE TABLE D90

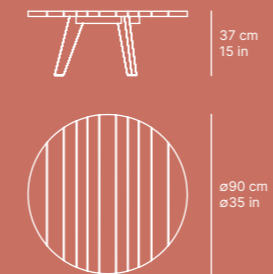

[24394.01.XX] COFFEE TABLE D135

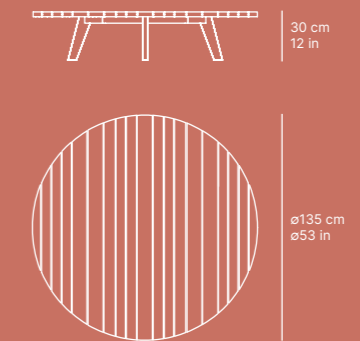

[24398] RECLINING LOUNGER

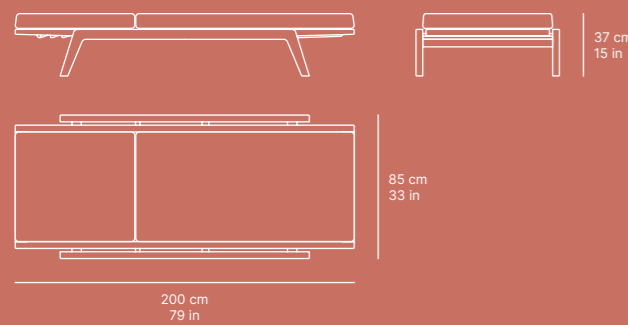

[24396.XX] SIDE TABLE D60

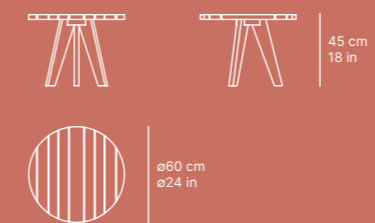

[24395.XX] SIDE TABLE 54x54

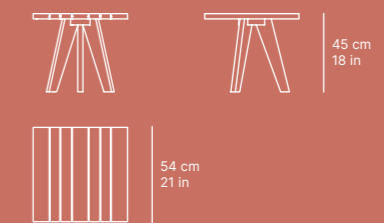

koro collection by eli gutierrez

La colección fusiona la cultura japonesa y la pasión por la artesanía. Inspirada en el Koro, un contenedor de incienso japonés de formas redondeadas, combina diseño orgánico con un tejido experimental. Su trenzado horizontal, logrado al mezclar cuerda y cincha, aporta sinuosidad y elegancia, vistiendo la estructura como si de una prenda de ropa se tratase y dotándola de una piel gráfica y marcada.

The collection merges Japanese culture with a passion for craftsmanship. Inspired by the Koro, a Japanese incense container with rounded shapes, it combines organic design with an experimental fabric. Its horizontal braiding, achieved by blending rope and webbing, brings fluidity and elegance, dressing the structure like a garment and endowing it with a bold, graphic skin.







01.

01. Lounge chair.



02.

02. High lounge chair.



diseñadora
designer

eli
gutierrez



Diseñadora cosmopolita formada en Valencia y Londres. Tras vivir en Milán y París y colaborar con destacados estudios, funda su propio estudio en 2017, desarrollando proyectos de producto, electrónica, instalaciones y textiles.

Su trabajo se distingue por una sensibilidad clara y elegante, enfocada en material, color, función y detalle. Sus diseños combinan poesía y funcionalidad, integrando artesanía y nuevas tecnologías para aportar innovación y carácter. Busca equilibrio entre atemporalidad y sencillez, creando objetos con identidad propia y un diseño refinado.

Cosmopolitan designer trained in Valencia and London. After living in Milan and Paris and collaborating with renowned studios, she founded her own studio in 2017, developing product, electronics, installations, and textile projects.

Her work stands out for its clear and elegant sensitivity, focusing on material, color, function, and detail. Her designs blend poetry and functionality, integrating craftsmanship and new technologies to bring innovation and character. She seeks a balance between timelessness and simplicity, creating objects with a distinct identity and refined design.

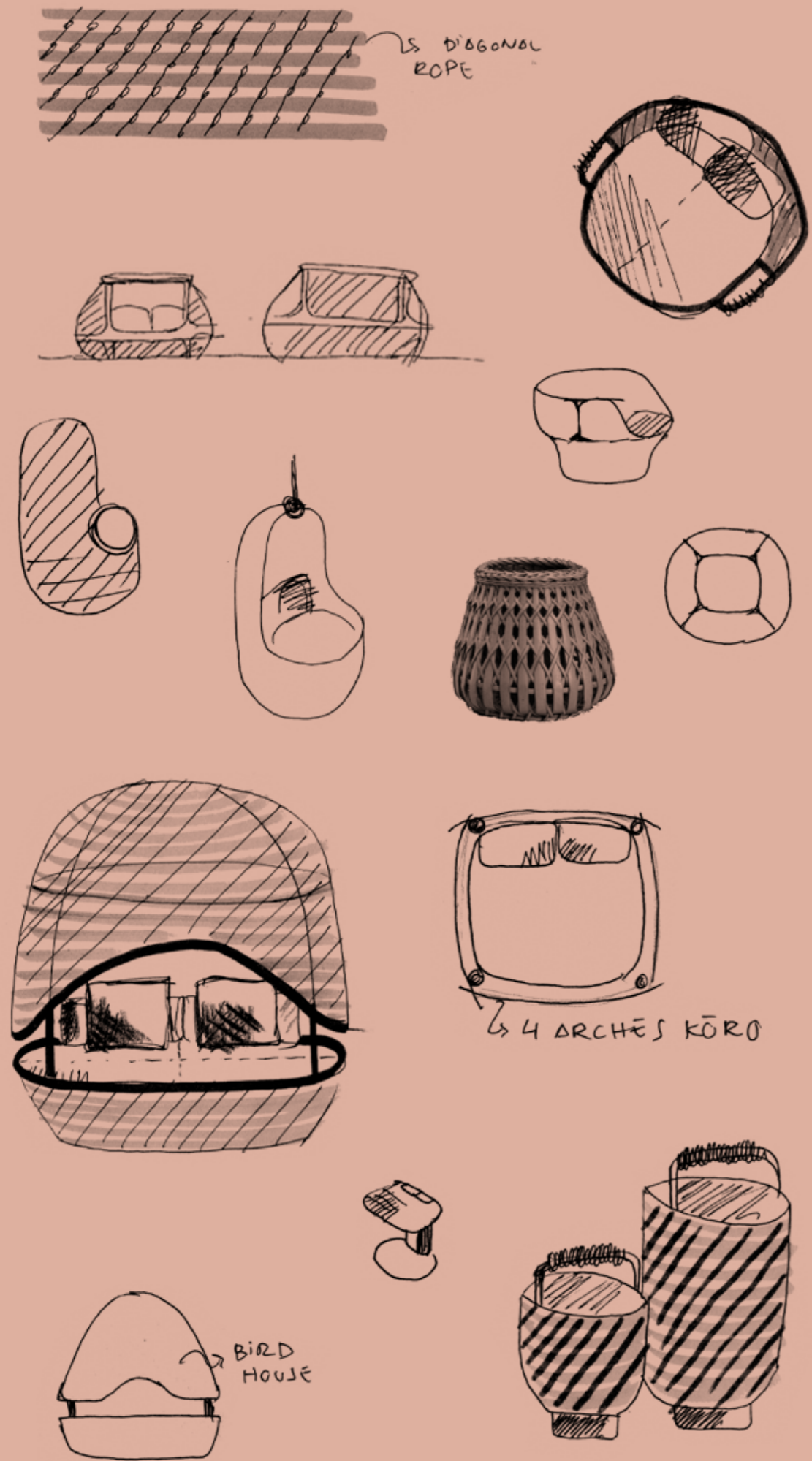



03.



04.

03. High swing + swing stand.

04. High swing.



05. Swing + swing stand.

06. Swing.

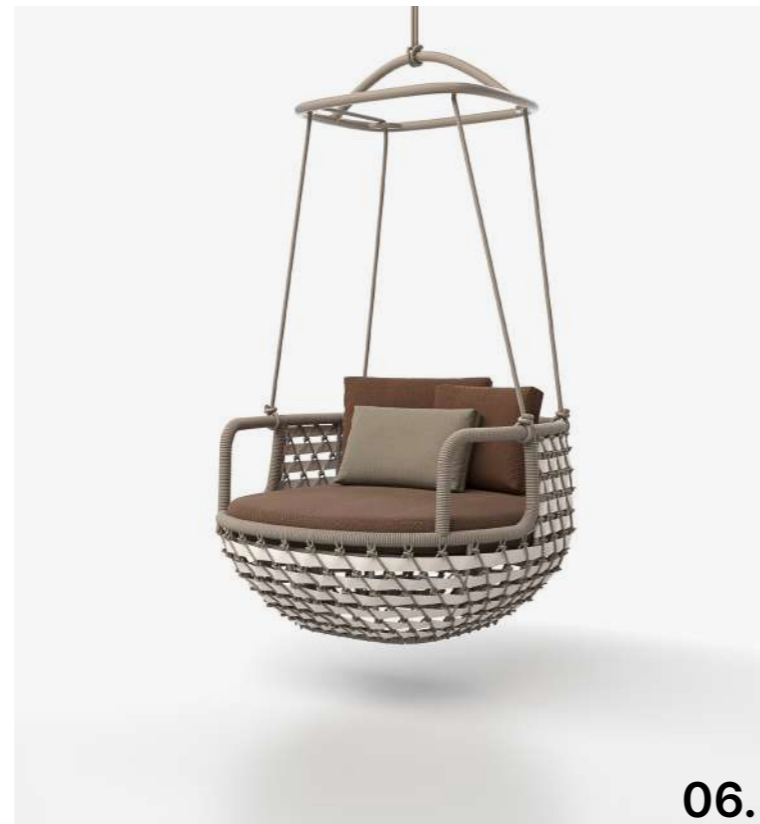





07.

07. Daybed low.



08.

08. Daybed high.





09.



10.

09. Side table full aluminium.

10. Side table teak wood.





11. Tray table full aluminium.

12. Tray table teak wood.



11.



12.



13.

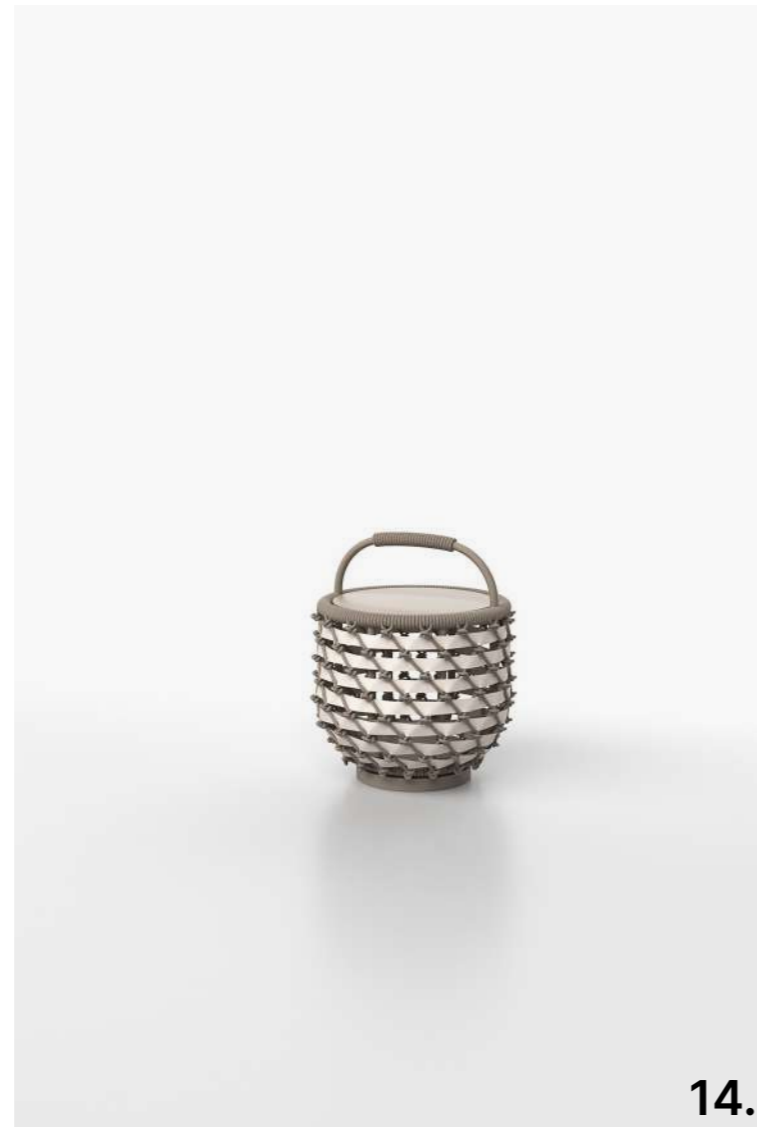

14.

13. Lamp L.

14. Lamp S.



technical

MATERIALS

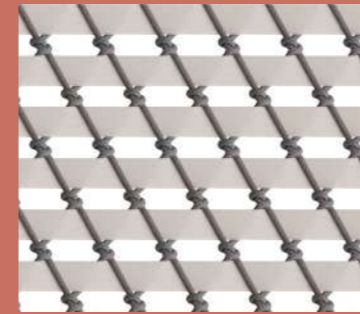

Claro Light
RAL 1013

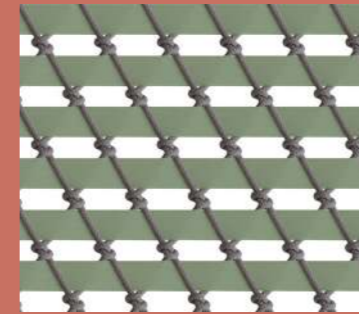

Verde Green
RAL 6021

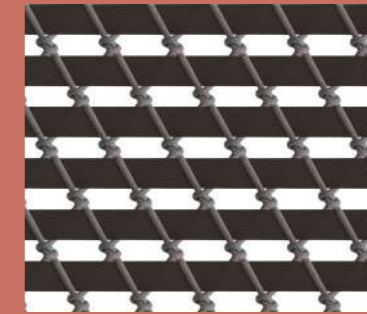

Oscuro Dark
RAL 8019

[24424.XX] LOUNGE CHAIR

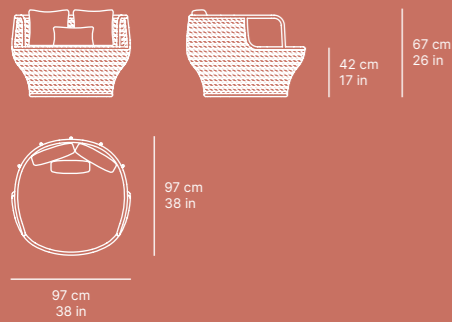

[24425.XX] HIGH LOUNGE CHAIR

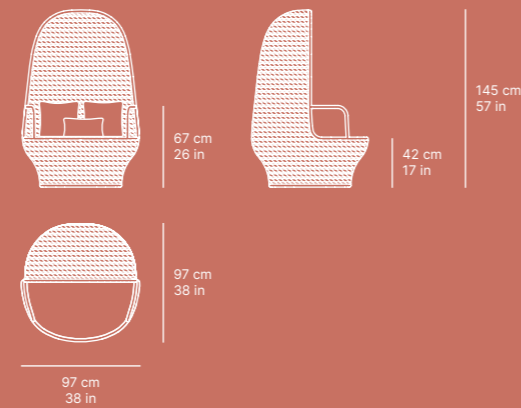

[24430.XX + 00082] SWING + SWING STAND

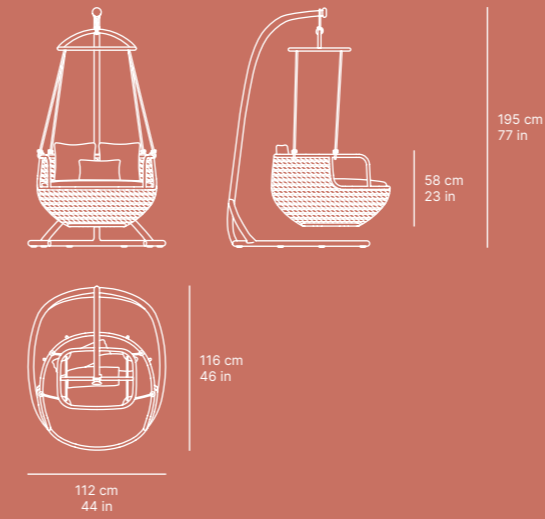

[24431.XX + 00082] HIGH SWING + SWING STAND

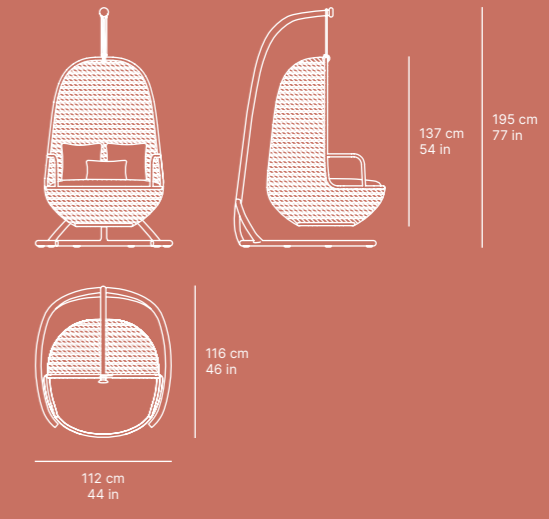

[24426.XX] DAYBED LOW

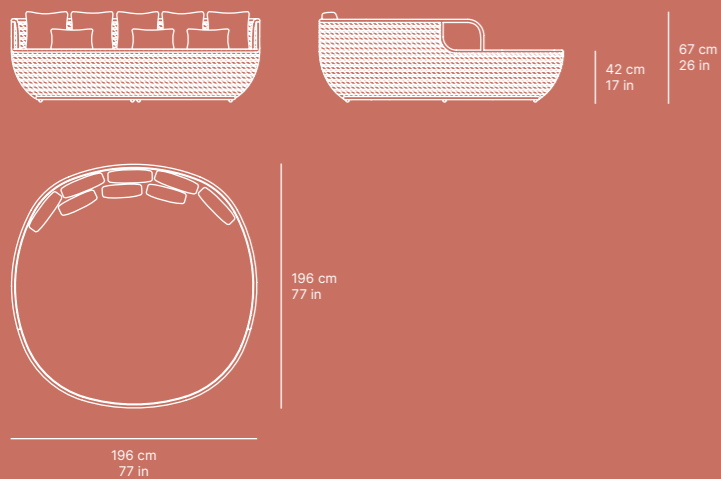

[24427.XX] DAYBED HIGH

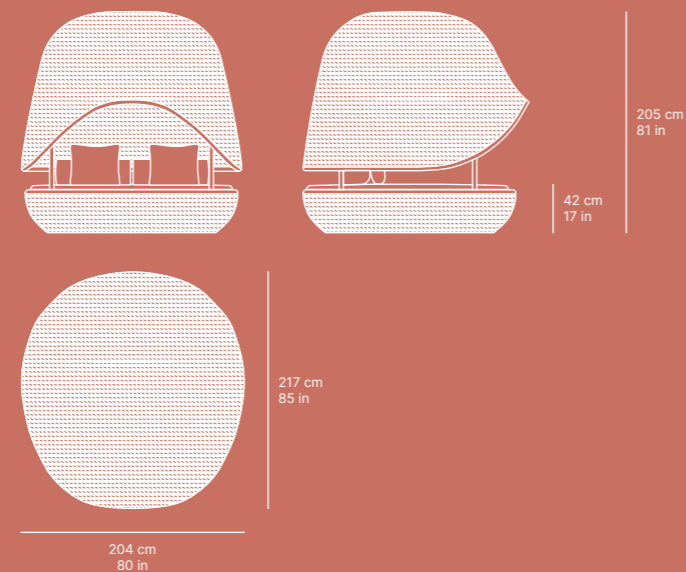

technical

MATERIALS

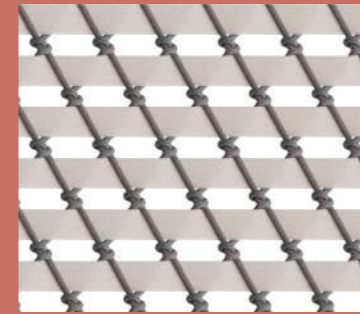

Claro Light
RAL 1013

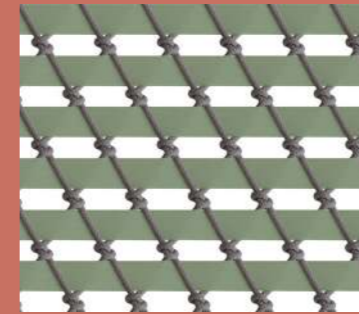

Verde Green
RAL 6021

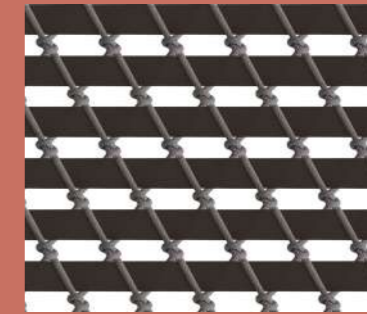

Oscuro Dark
RAL 8019

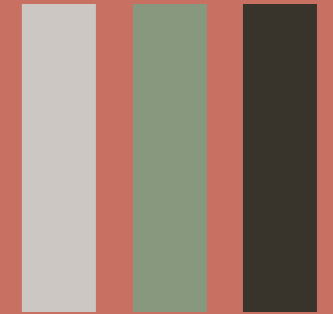

Aluminio Aluminium
RAL 1013 / 6021 / 8019

[24430.XX] SWING

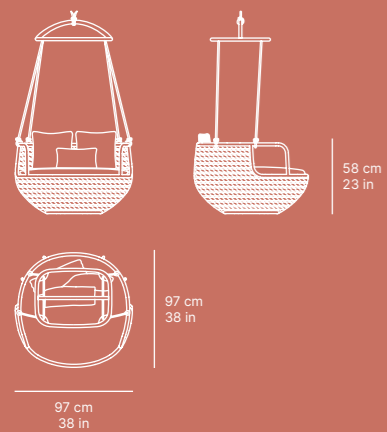

[24431.XX] HIGH SWING

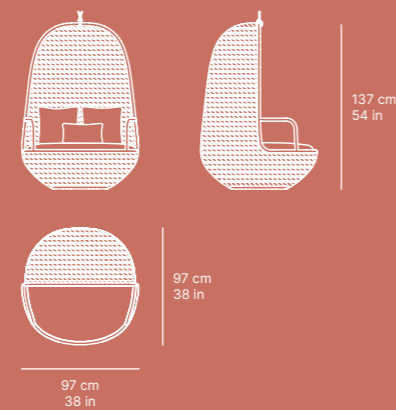

[00082] SWING STAND

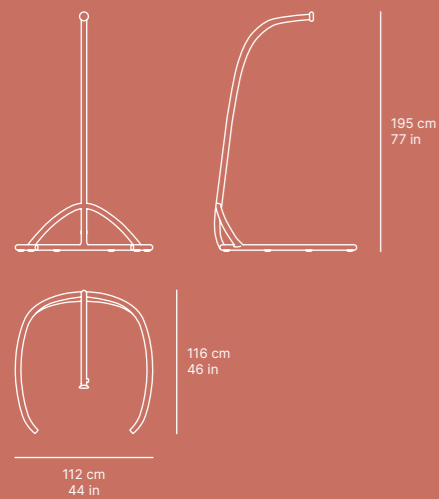

[24428.XX] SIDE TABLE

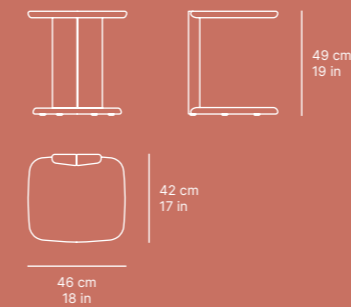

[24429.XX] TRAY TABLE

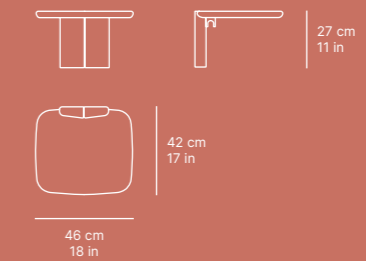

[24439.XX] LAMP L

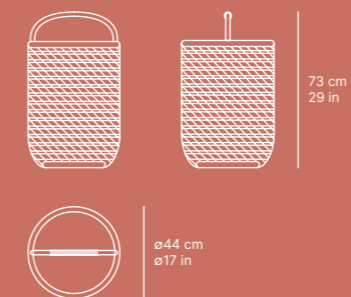

[24438.XX] LAMP S

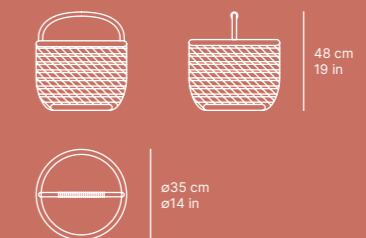

serra collection by kar durán & miguel lópez

La colección se nutre de la esencia de las clásicas sillas de ratán, evocando recuerdos de barrio, tradiciones familiares y veranos nostálgicos. Con un diseño atrevido, combina el trenzado tradicional del asiento, con patas cónicas en metal que rompen con la estética convencional. Su asiento, diseñado como un abrazo que envuelve y acoge, añade un confort único, mientras la estructura ejerce de cesta. Una colección especial elegante y divertida, diseñada para que se adapte a cualquier entorno.

The collection draws inspiration from classic rattan chairs, evoking neighborhood memories, family traditions, and nostalgic summers. With a bold design, it combines the traditional woven seat with tapered metal legs that break conventional aesthetics. Its seat, designed as a welcoming embrace, adds unique comfort, while the structure acts as a basket. A special, elegant, and playful collection, designed to adapt to any setting.







01.



02.

01. Sofa.

02. Lounge chair.

03. Love seat.



03.





diseñadores
designers

kar durán & miguel lópez



Kar Durán y Miguel López se inspiran en la memoria emocional para crear diseños únicos. Se centran en cómo los objetos hacen sentir a las personas y se esfuerzan por trabajar desde ese punto de partida.

La amistad, el humor y el amor por la belleza de los objetos son los pilares fundamentales de sus propuestas; juntos han colaborado con algunas de las empresas más destacadas de la industria del mueble.

Kar Durán and Miguel López are inspired by emotional memory to create unique designs. They focus on how objects make people feel and strive to work from that starting point.

Friendship, humour and love for the beauty of objects are the fundamental pillars of their proposals; together they have collaborated with some of the most prominent companies in the furniture industry.

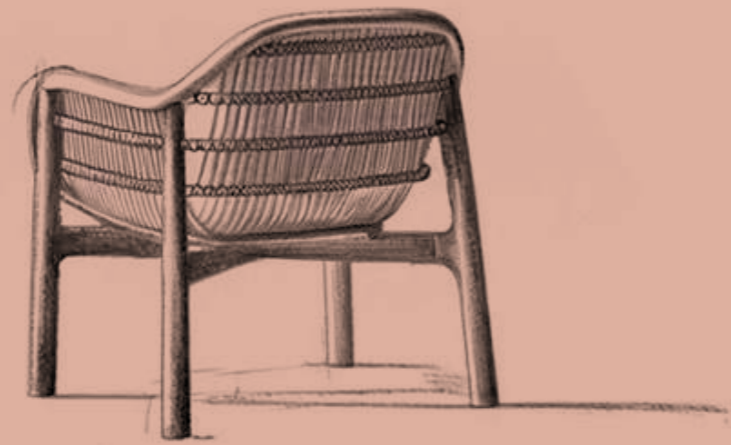

F1



F2

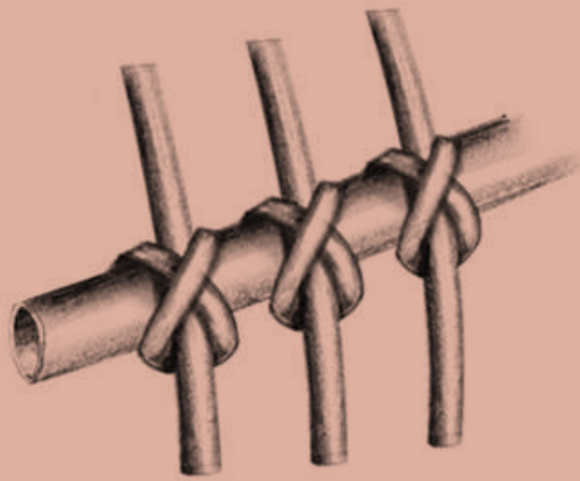

F3



F4





04.

04. Daybed low.



05.

05. Daybed high.



06. Reclining lounge.



06.





07.

07. Dining chair.



08.



09.

08. Dining table 300.

09. Dining table 240.



10. Bar stool.

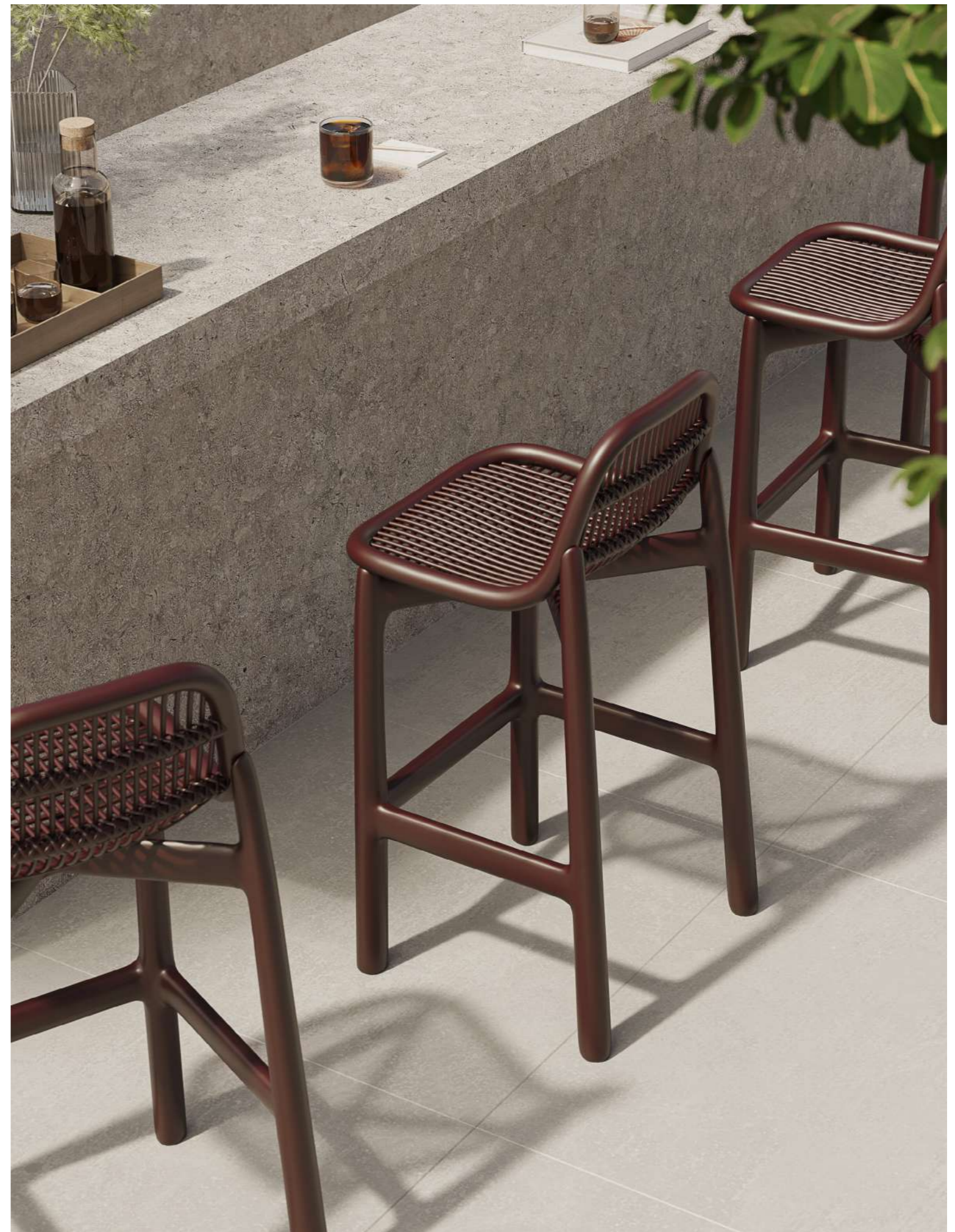



11.



12.

11. High side table.

12. Low side table.

13. Square coffee table.

14. Rectangular coffee table.



13.



14.

technical

MATERIALS



Aluminio *Aluminium*
Burgundy RAL 8015



Aluminio *Aluminium*
White Wash

[24411.XX] LOUNGE CHAIR

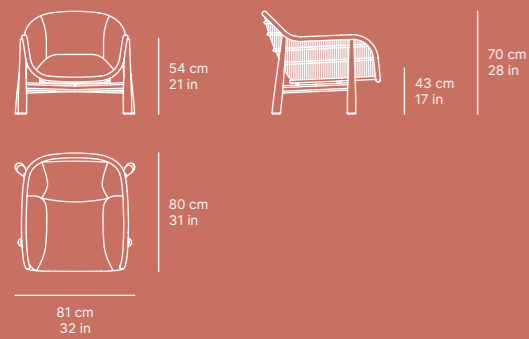

[24412.XX] LOVE SEAT

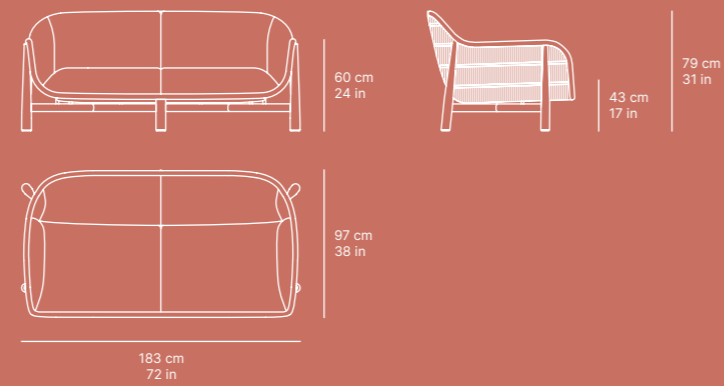

[24418.XX] RECLAINING LOUNGER

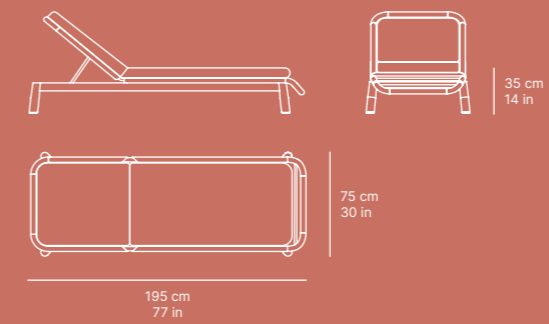

[24416.XX] DAYBED LOW

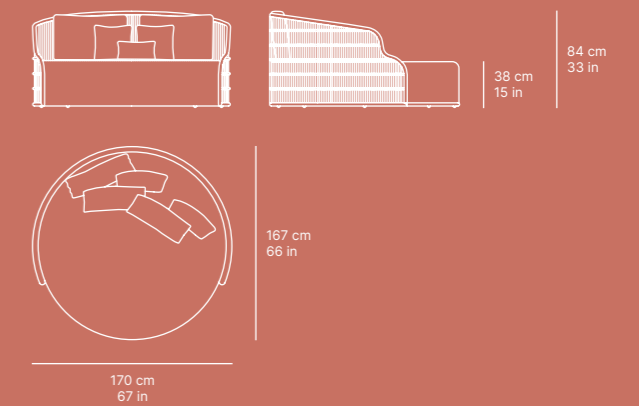

[24413.XX] SOFA

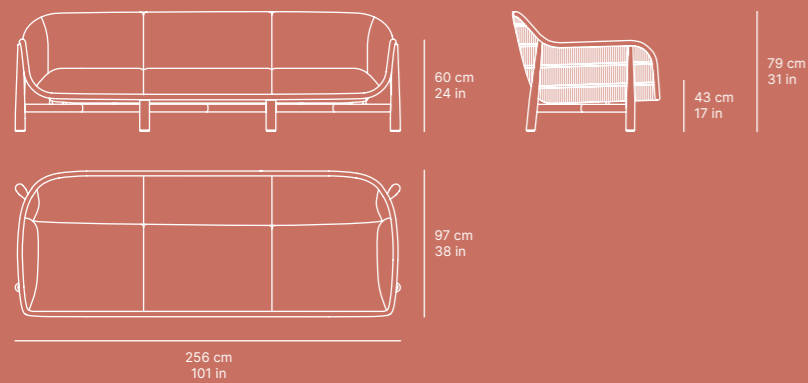

[24423.XX] DAYBED HIGH

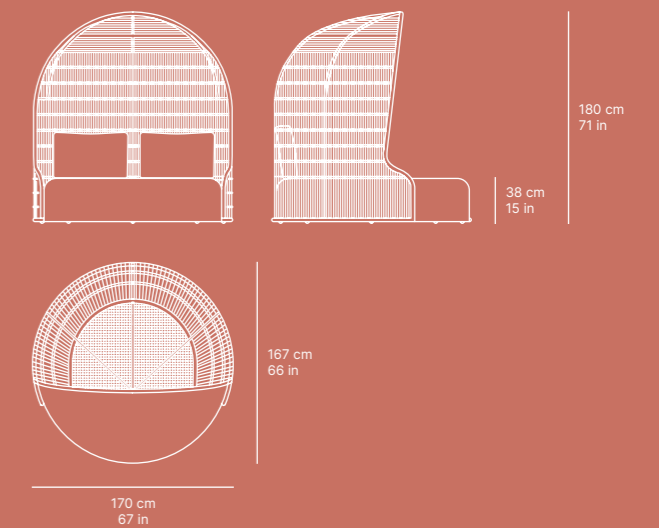

technical

MATERIALS



Aluminio *Aluminium*
Burgundy RAL 8015



Aluminio *Aluminium*
White Wash

[24410.XX] DINING CHAIR

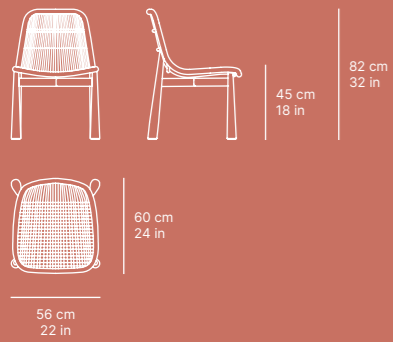

[24419.XX] BAR STOOL

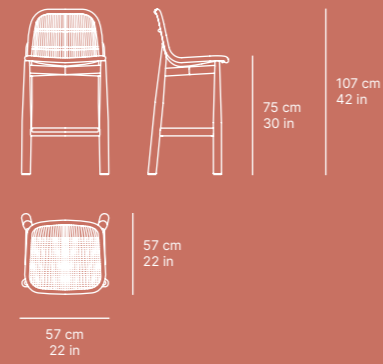

[24417.XX] DINING TABLE 240

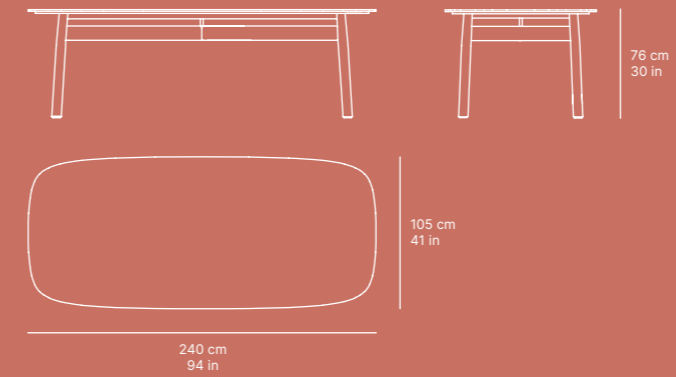

[24420.XX] DINING TABLE 300

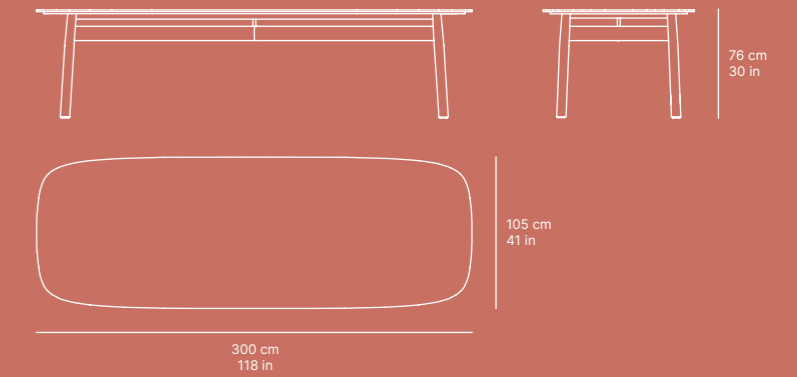

technical

[24414.XX] RECTANGULAR COFFEE TABLE

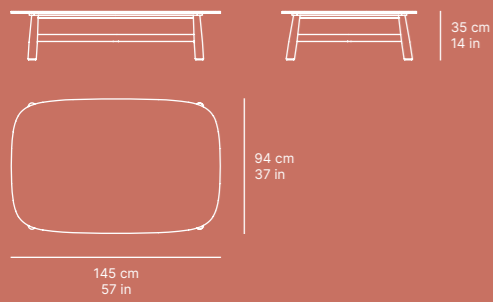

[24421.XX] SQUARE COFFEE TABLE

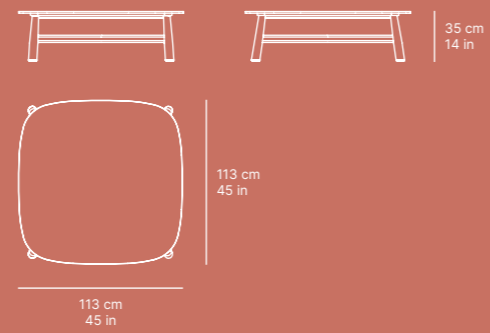

MATERIALS



Aluminio *Aluminium*
Burgundy RAL 8015



Aluminio *Aluminium*
White Wash

[24415.XX] HIGH SIDE TABLE

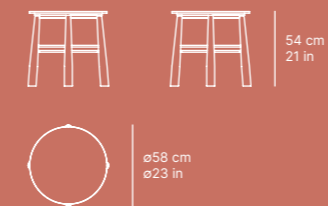

[24422.XX] LOW SIDE TABLE

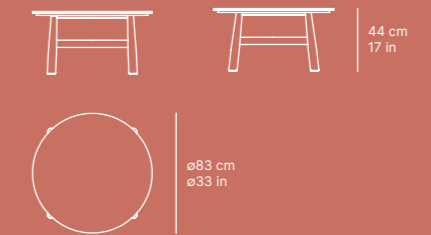

eki collection by silvia ceñal

La colección destaca por su característica curva envolvente, presente en cada pieza diseñada. Este elemento aporta una estética fluida y un diseño ergonómico que, en los asientos, abraza al usuario, brindando confort y personalidad. En las mesas, esa misma curva envolvente permite crear estructuras únicas y singulares, que rompen con lo convencional. Además, el uso intencionado de madera en listones de diferentes anchos añade un toque irreverente y divertido a la colección, fusionando funcionalidad y creatividad en cada detalle.

The collection stands out for its distinctive enveloping curve, present in every designed piece. This element provides a fluid aesthetic and an ergonomic design that, in seating, embraces the user, offering comfort and character. In tables, the same curve creates unique and singular structures that break away from convention. Additionally, the intentional use of wooden slats in varying widths adds a playful and irreverent touch, blending functionality and creativity in every detail.







01.

01. Dining armchair.



02.

02. Dining armchair rope.





diseñadora
designer



silvia
ceñal



Su enfoque como diseñadora se basa en descubrir la esencia de cada proyecto con una mirada curiosa y abierta a la experimentación. Desde su ciudad natal, Donostia, encuentra inspiración en su entorno para explorar materiales, texturas y colores, buscando una conexión auténtica con cada cliente.

Equilibra estética y funcionalidad, evitando tendencias pasajeras para crear objetos duraderos y elegantes. Convencida de que las cosas bien hechas marcan la diferencia, diseña piezas atemporales que hablan por sí mismas. Abierta a nuevos retos, colabora con clientes internacionales que valoran su visión fresca y su capacidad para crear diseños perdurables.

Her approach as a designer is based on discovering the essence of each project with a curious mindset and openness to experimentation. From her hometown, Donostia, she finds inspiration in her surroundings to explore materials, textures, and colors, always seeking a genuine connection with each client.

She balances aesthetics and functionality, avoiding fleeting trends to create durable and elegant objects. Convinced that well-made things make a difference, she designs timeless pieces that speak for themselves. Open to new challenges, she collaborates with international clients who value her fresh vision and ability to create enduring designs.



03. Bar stool.



04.

04. Bar stool rope.

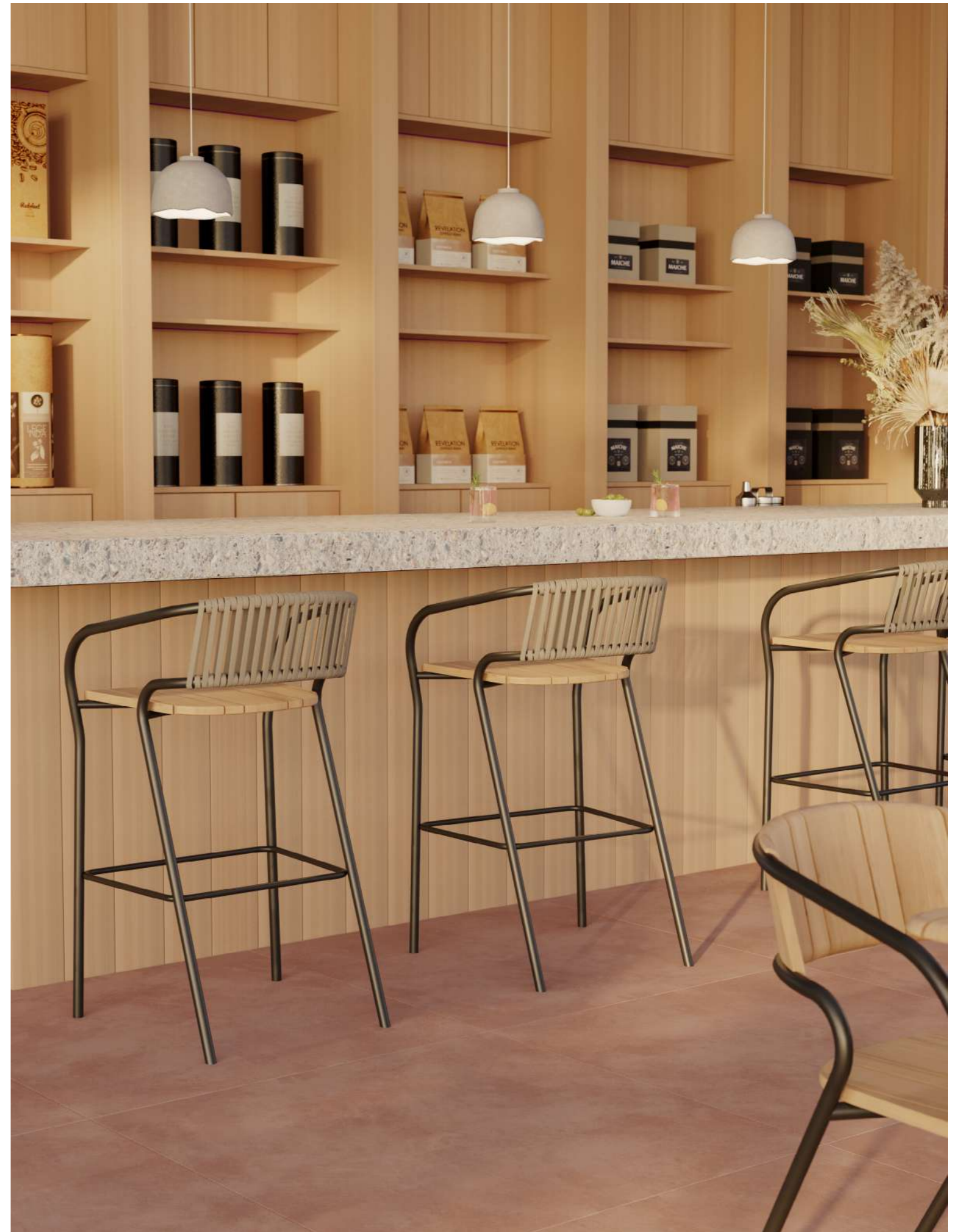



05.

05. Dining table.



06.

06. Bar table.

technical

MATERIALS



Madera de teca
Teak wood



Aluminio Aluminium
White Wash



Aluminio Aluminium
Carbon Matte



Cuerda plana Flat rope
Atmospher

[24432.XX] DINING ARMCHAIR

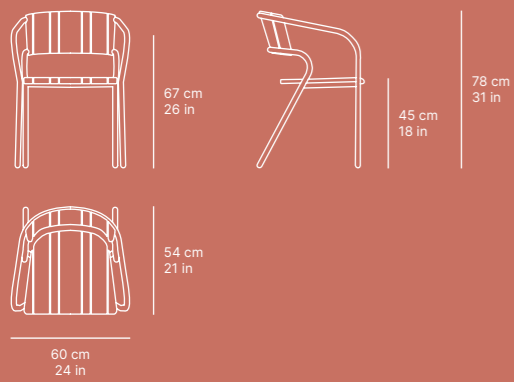

[24433.XX] DINING ARMCHAIR ROPE

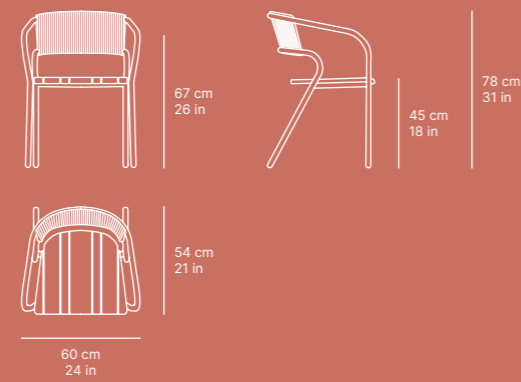

[24434.XX] DINING TABLE

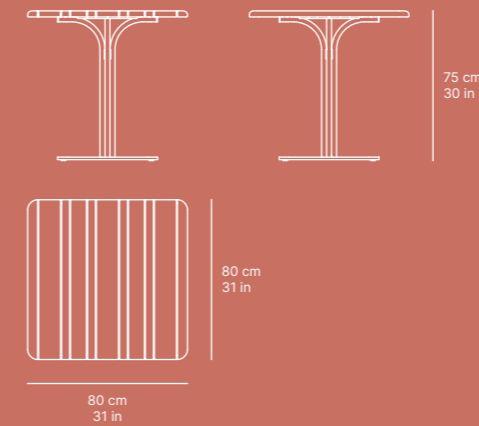

[24437.XX] BAR TABLE

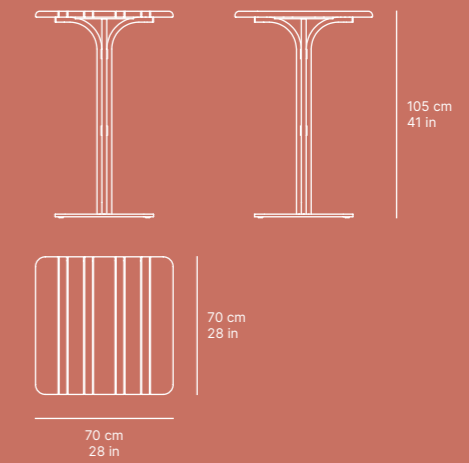

[24435.XX] BAR STOOL

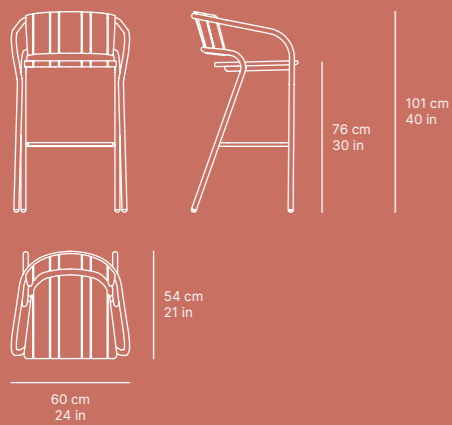

[24436.XX] BAR STOOL ROPE

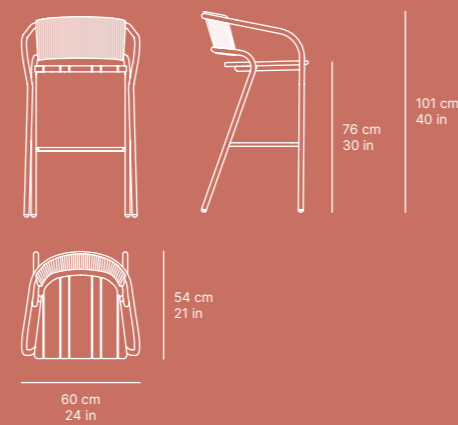

materials

materials

fabrics

PANAMA

STANDARD

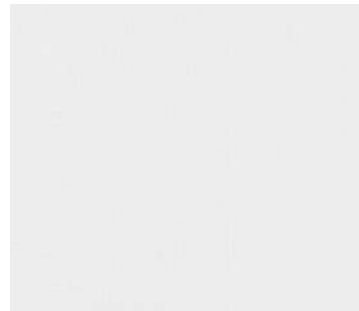

20208 Optik

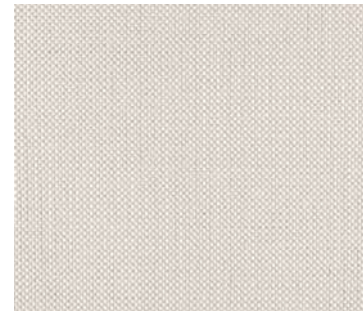

1320 Bone



1322 Marble



20084 Cream

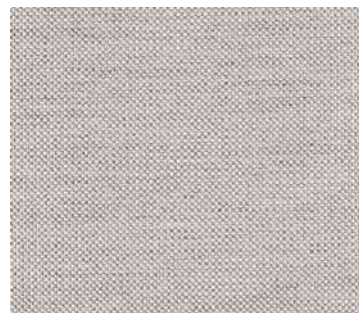

3658 Cloud



1781 Escarcha



20081 Salvia



3660 Cherry

LISO

STANDARD



1228 Sand

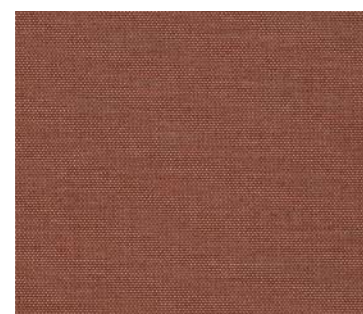

20203 Umbra



20204 Laguna



20205 Hollin

OTTOMAN

PREMIUM



20066 Pergamino



20067 Gris Porcelana



20071 Umbra



20072 Laguna



20073 Stone Grey

EGO

PREMIUM

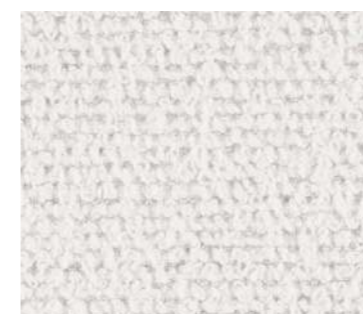

20249 Eggshell



20253 Salvia

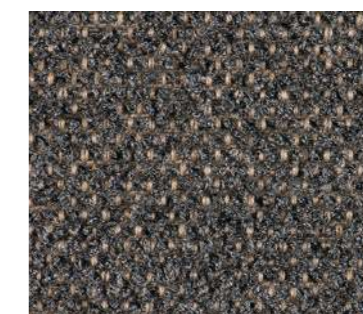

20254 Storm

materials

RITMO

PREMIUM



20094 Duna

20093 Umbra

20092 Celadon

20095 Laguna



20084 Cream

20085 Sand

20087 Cemento

fabrics

SUNSET

PREMIUM



20235 Marble

20239 Fresh

20241 Limestone

CHEVIOT

PREMIUM

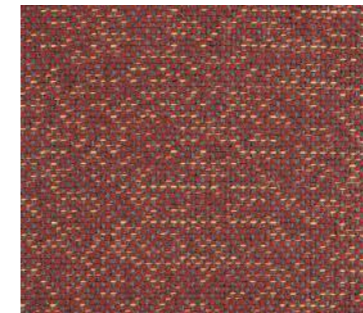

1707 Terra

1709 Stone

materials

dekton

Dekton Nacre
Kraftizen



Dekton Nebbia
Pietra Kode



Dekton VK03
Grigio Pietra Kode



VK04 Grafite
Pietra Kode

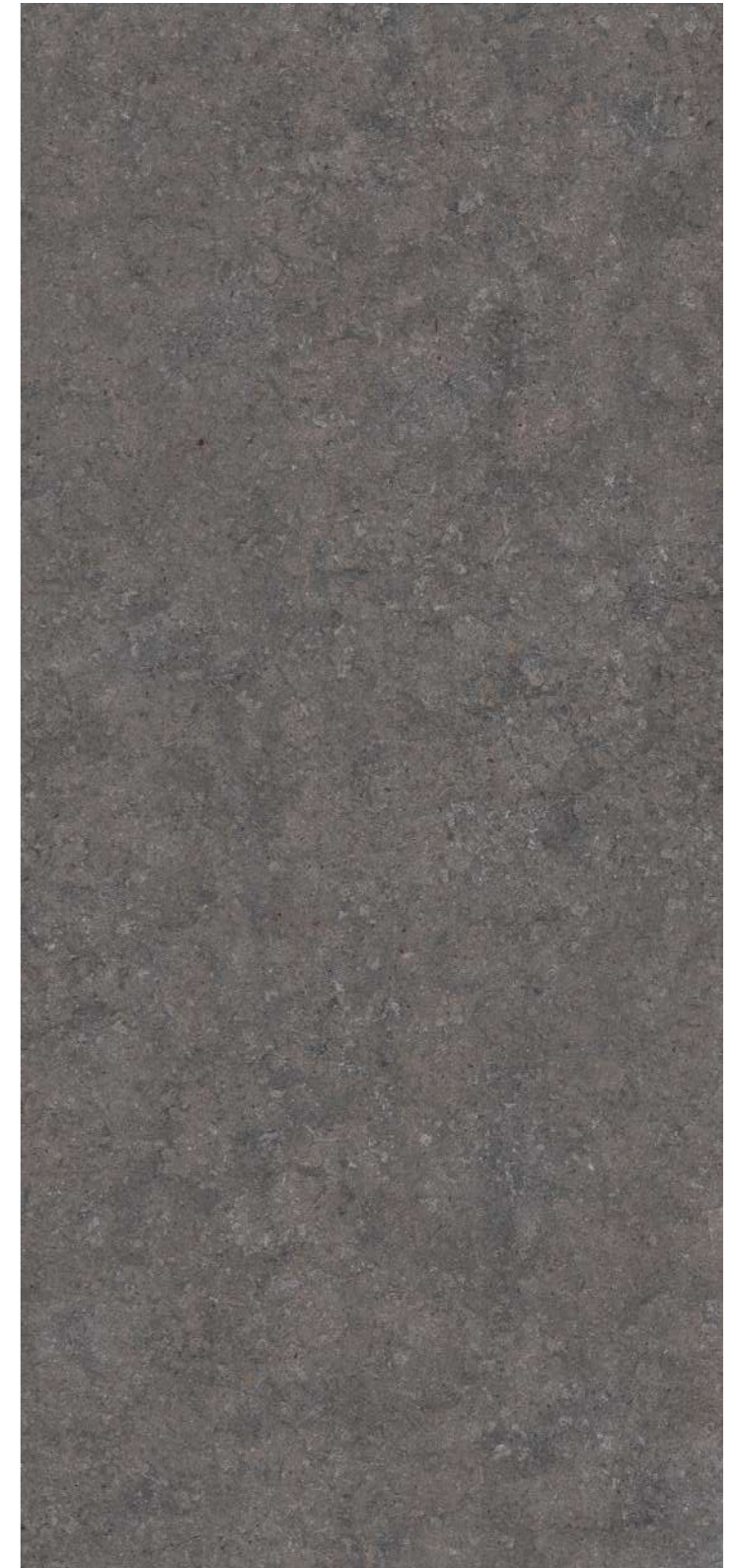

Product Direction
Fat-Iron Studio

Concept, Art Direction and Visuals
Inmenso Studio

Writing Text
SKLD Studio

Logo Concept
Jiménez De Nalda ®

Copyright 2025 SKLD Studio
All rights reserved

